

OPERATION AND PARTS MANUAL



MQ POWER

MODEL MQP20P 20KW STANDBY GENERATOR (PERKINS 404D-22 DIESEL ENGINE)

Revision #1 (11/28/11)

To find the latest revision of this
publication, visit our website at:
www.multiquip.com



THIS MANUAL MUST ACCOMPANY THE EQUIPMENT AT ALL TIMES.



CALIFORNIA — Proposition 65 Warning

Diesel engine exhaust and some of its constituents are known to the State of California to cause cancer, birth defects and other reproductive harm.

TABLE OF CONTENTS

MQP20P Standby Generator

Proposition 65 Warning	2
Table Of Contents	4
Parts Ordering Procedures	5
Safety Information	6-11
Specifications	12
Dimensions	13
Installation	14-15
General Information	16-17
Major Components	18
Basic Engine Components	19
Digital Controller Panel	20
Connector Outlet Box And Main Circuit Breaker ...	21
Load Application/Generator Output	22
Inspection/Setup	23-26
Startup	27-29
Protective Devices	30
Transporting	31
Maintenance	32-35
Troubleshooting (Generator)	36
Troubleshooting (Engine)	37
Troubleshooting (Controller)	38-39
Troubleshooting (Voltage Regulator)	40
Maintenance Parts Locator	41
Generator Wiring Diagram (Single Phase)	42-43
Generator Wiring Diagram (Three Phase)	44-45
Explanation Of Code In Remarks Column	46
Suggested Spare Parts	47

Component Drawings

Housing Assy.	48-49
Engine And Generator Mounting Assy.	50-51
Fuel Assy.	52-53
Electrical Assy.	54-55
Jacket Water Heater Assy.	56-57
Solenoid Assy.	5-59
Radiator Assy.	60-61
Air Filter Assy.	62-63
Engine Exhaust Assy.	64-65
Engine Oil Assy.	66-67
Control Panel Assy.	68-69
Controller Assy.	70-71
Saddlebox Assy.	72-73
Circuit Breaker Assy.	74-5
Camlok Assy.	76-77
Terms And Conditions Of Sale — Parts	78

NOTICE

Specifications and part numbers are subject to change without notice.

PARTS ORDERING PROCEDURES

Ordering parts has never been easier! Choose from three easy options:

Effective:
January 1st, 2006

www.multiquip.com



Order via Internet (Dealers Only):

Order parts on-line using Multiquip's SmartEquip website!

- View Parts Diagrams
- Order Parts
- Print Specification Information



If you have an MQ Account, to obtain a Username and Password, E-mail us at: parts@multiquip.com.

To obtain an MQ Account, contact your District Sales Manager for more information.

Goto www.multiquip.com and click on **Order Parts** to log in and save!

Use the **internet** and qualify for a **5% Discount** on *Standard orders* for all orders which include complete part numbers.*

Note: Discounts Are Subject To Change

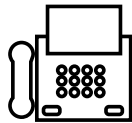

Order via Fax (Dealers Only):

All customers are welcome to order parts via Fax.

Domestic (US) Customers dial:
1-800-6-PARTS-7 (800-672-7877)

Fax your order in and qualify for a **2% Discount** on *Standard orders* for all orders which include complete part numbers.*

Note: Discounts Are Subject To Change



Order via Phone: Domestic (US) Dealers Call:
1-800-427-1244

Non-Dealer Customers:

Contact your local Multiquip Dealer for parts or call 800-427-1244 for help in locating a dealer near you.



International Customers should contact their local Multiquip Representatives for Parts Ordering information.

When ordering parts, please supply:

- | | |
|---|--|
| <input type="checkbox"/> Dealer Account Number | <input type="checkbox"/> Specify Preferred Method of Shipment: |
| <input type="checkbox"/> Dealer Name and Address | <input checked="" type="checkbox"/> UPS/Fed Ex <input checked="" type="checkbox"/> DHL |
| <input type="checkbox"/> Shipping Address (if different than billing address) | <input type="checkbox"/> Priority One <input checked="" type="checkbox"/> Truck |
| <input type="checkbox"/> Return Fax Number | <input type="checkbox"/> Ground |
| <input type="checkbox"/> Applicable Model Number | <input type="checkbox"/> Next Day |
| <input type="checkbox"/> Quantity, Part Number and Description of Each Part | <input type="checkbox"/> Second/Third Day |

NOTICE

All orders are treated as *Standard Orders* and will ship the same day if received prior to 3PM PST.

WE ACCEPT ALL MAJOR CREDIT CARDS!



SAFETY INFORMATION

Do not operate or service the equipment before reading the entire manual. Safety precautions should be followed at all times when operating this equipment. Failure to read and understand the safety messages and operating instructions could result in injury to yourself and others.

SAFETY MESSAGES

The four safety messages shown below will inform you about potential hazards that could injure you or others. The safety messages specifically address the level of exposure to the operator and are preceded by one of four words: **DANGER**, **WARNING**, **CAUTION** or **NOTICE**.

SAFETY SYMBOLS

 **DANGER**

Indicates a hazardous situation which, if not avoided, **WILL** result in **DEATH** or **SERIOUS INJURY**.

 **WARNING**

Indicates a hazardous situation which, if not avoided, **COULD** result in **DEATH** or **SERIOUS INJURY**.







 **CAUTION**

Indicates a hazardous situation which, if not avoided, **COULD** result in **MINOR** or **MODERATE INJURY**.

NOTICE

Addresses practices not related to personal injury.

Potential hazards associated with the operation of this equipment will be referenced with hazard symbols which may appear throughout this manual in conjunction with safety messages.

Symbol	Safety Hazard
	Lethal exhaust gas hazards
	Explosive fuel hazards
	Burn hazards
	Overspeed hazards
	Rotating parts hazards
	Pressurized fluid hazards
	Electric shock hazards

SAFETY INFORMATION

GENERAL SAFETY

CAUTION

- **NEVER** operate this equipment without proper protective clothing, shatterproof glasses, respiratory protection, hearing protection, steel-toed boots and other protective devices required by the job or city and state regulations.



- **NEVER** operate this equipment when not feeling well due to fatigue, illness or when under medication. 
- **NEVER** operate this equipment under the influence of drugs or alcohol.



- **ALWAYS** check the equipment for loosened threads or bolts before starting.
- **DO NOT** use the equipment for any purpose other than its intended purposes or applications.

NOTICE

- This equipment should only be operated by trained and qualified personnel 18 years of age and older.
- Whenever necessary, replace nameplate, operation and safety decals when they become difficult read.
- Manufacturer does not assume responsibility for any accident due to equipment modifications. Unauthorized equipment modification will void all warranties.

- **NEVER** use accessories or attachments that are not recommended by MQ Power for this equipment. Damage to the equipment and/or injury to user may result.

- **ALWAYS** know the location of the nearest **fire extinguisher**.



- **ALWAYS** know the location of the nearest **first aid kit**.



- **ALWAYS** know the location of the nearest phone or **keep a phone on the job site**. Also, know the phone numbers of the nearest **ambulance, doctor and fire department**. This information will be invaluable in the case of an emergency.

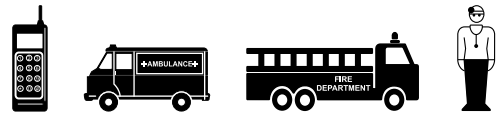

GENERATOR SAFETY

DANGER

- **NEVER** operate the equipment in an explosive atmosphere or near combustible materials. An explosion or fire could result causing severe **bodily harm or even death**.



WARNING

- **NEVER** disconnect any **emergency or safety devices**. These devices are intended for operator safety. Disconnection of these devices can cause severe injury, bodily harm or even death. Disconnection of any of these devices will void all warranties.

CAUTION

- **NEVER** lubricate components or attempt service on a running machine.

NOTICE

- **ALWAYS** ensure generator is on level ground before use.
- **ALWAYS** keep the machine in proper running condition.
- Fix damage to machine and replace any broken parts immediately.
- **ALWAYS** store equipment properly when it is not being used. Equipment should be stored in a clean, dry location out of the reach of children and unauthorized personnel

SAFETY INFORMATION

ENGINE SAFETY

DANGER

- The engine fuel exhaust gases contain poisonous carbon monoxide. This gas is colorless and odorless, and can cause death if inhaled.
- The engine of this equipment requires an adequate free flow of cooling air. **NEVER** operate this equipment in any enclosed or narrow area where free flow of the air is restricted. If the air flow is restricted it will cause injury to people and property and serious damage to the equipment or engine.

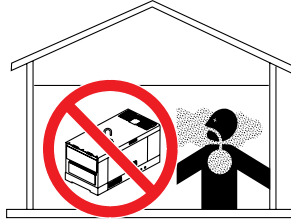

WARNING

- **DO NOT** place hands or fingers inside engine compartment when engine is running.
- **NEVER** operate the engine with heat shields or guards removed.
- Keep fingers, hands hair and clothing away from all moving parts to prevent injury.
- **DO NOT** remove the radiator cap while the engine is hot. High pressure boiling water will gush out of the radiator and severely scald any persons in the general area of the generator.
- **DO NOT** remove the coolant drain plug while the engine is hot. Hot coolant will gush out of the coolant tank and severely scald any persons in the general area of the generator.
- **DO NOT** remove the engine oil drain plug while the engine is hot. Hot oil will gush out of the oil tank and severely scald any persons in the general area of the generator.



CAUTION

- **NEVER** touch the hot exhaust manifold, muffler or cylinder. Allow these parts to cool before servicing equipment.



NOTICE

- **NEVER** run engine without an air filter or with a dirty air filter. Severe engine damage may occur. Service air filter frequently to prevent engine malfunction.
- **NEVER** tamper with the factory settings of the engine or engine governor. Damage to the engine or equipment can result if operating in speed ranges above the maximum allowable.
- Wet stacking is a common problem with diesel engines which are operated for extended periods with light or no load applied. When a diesel engine operates without sufficient load (less than 40% of the rated output), it will not operate at its optimum temperature. This will allow unburned fuel to accumulate in the exhaust system, which can foul the fuel injectors, engine valves and exhaust system, including turbochargers, and reduce the operating performance.



In order for a diesel engine to operate at peak efficiency, it must be able to provide fuel and air in the proper ratio and at a high enough engine temperature for the engine to completely burn all of the fuel.

Wet stacking does not usually cause any permanent damage and can be alleviated if additional load is applied to relieve the condition. It can reduce the system performance and increase maintenance. Applying an increasing load over a period of time until the excess fuel is burned off and the system capacity is reached usually can repair the condition. This can take several hours to burn off the accumulated unburned fuel.

- State Health Safety Codes and Public Resources Codes specify that in certain locations, spark arresters must be used on internal combustion engines that use hydrocarbon fuels. A spark arrester is a device designed to prevent accidental discharge of sparks or flames from the engine exhaust. Spark arresters are qualified and rated by the United States Forest Service for this purpose. In order to comply with local laws regarding spark arresters, consult the engine distributor or the local Health and Safety Administrator.

SAFETY INFORMATION

FUEL SAFETY

DANGER

- **DO NOT** start the engine near spilled fuel or combustible fluids. Diesel fuel is extremely flammable and its vapors can cause an explosion if ignited.
- **ALWAYS** refuel in a well-ventilated area, away from sparks and open flames.
- **ALWAYS** use extreme caution when working with **flammable** liquids.
- **DO NOT** fill the fuel tank while the engine is running or hot.
- **DO NOT** overfill tank, since spilled fuel could ignite if it comes into contact with hot engine parts or sparks from the ignition system.
- Store fuel in appropriate containers, in well-ventilated areas and away from sparks and flames.
- **NEVER** use fuel as a cleaning agent.
- **DO NOT** smoke around or near the equipment. Fire or explosion could result from fuel vapors or if fuel is spilled on a hot engine.



TOWING SAFETY

CAUTION

- Check with your local county or state safety towing regulations, in addition to meeting **Department of Transportation (DOT) Safety Towing Regulations**, before towing your generator.
- Refer to MQ Power trailer manual for additional safety information.
- In order to reduce the possibility of an accident while transporting the generator on public roads, **ALWAYS** make sure the trailer that supports the generator and the towing vehicle are mechanically sound and in good operating condition.
- **ALWAYS** shutdown engine before transporting



- Make sure the hitch and coupling of the towing vehicle are rated equal to, or greater than the trailer “gross vehicle weight rating.”
- **ALWAYS** inspect the hitch and coupling for wear. **NEVER** tow a trailer with defective hitches, couplings, chains, etc.
- Check the tire air pressure on both towing vehicle and trailer. **Trailer tires should be inflated to 50 psi cold.** Also check the tire tread wear on both vehicles.
- **ALWAYS** make sure the trailer is equipped with a **safety chain**.
- **ALWAYS** properly attach trailer’s safety chains to towing vehicle.
- **ALWAYS** make sure the vehicle and trailer directional, backup, brake and trailer lights are connected and working properly.
- DOT Requirements include the following:
 - Connect and test electric brake operation.
 - Secure portable power cables in cable tray with tie wraps.
- The maximum speed for highway towing is **55 MPH** unless posted otherwise. Recommended off-road towing is not to exceed **15 MPH** or less depending on type of terrain.
- Avoid sudden stops and starts. This can cause skidding, or jack-knifing. Smooth, gradual starts and stops will improve towing.
- Avoid sharp turns to prevent rolling.
- Trailer should be adjusted to a level position at all times when towing.
- Raise and lock trailer wheel stand in up position when towing.
- Place **chock blocks** underneath wheel to prevent **rolling** while parked.
- Place **support blocks** underneath the trailer’s bumper to prevent **tipping** while parked.
- Use the trailer’s swivel jack to adjust the trailer height to a level position while parked.

SAFETY INFORMATION

ELECTRICAL SAFETY

DANGER

- **DO NOT** touch output terminals during operation. Contact with output terminals during operation can cause **electrocution, electrical shock or burn.**



- The electrical voltage required to operate the generator can cause severe injury or even death through physical contact with live circuits. Turn generator and all circuit breakers **OFF** before performing maintenance on the generator or making contact with output terminals.

- **NEVER** insert any objects into the output receptacles during operation. This is extremely dangerous. The possibility exists of **electrical shock, electrocution or death.**



- Backfeed to a utility system can cause **electrocution** and/or property damage. **NEVER** connect the generator to a building's electrical system without a transfer switch or other approved device. All installations should be performed by a **licensed electrician** in accordance with all applicable laws and electrical codes. Failure to do so could result in electrical shock or burn, causing **serious injury or even death.**



Power Cord/Cable Safety

DANGER

- **NEVER** let power cords or cables **lay in water.**
- **NEVER stand in water** while AC power from the generator is being transferred to a load.
- **NEVER** use **damaged** or **worn** cables or cords when connecting equipment to generator. Inspect for cuts in the insulation.
- **NEVER** grab or touch a live power cord or cable with wet hands. The possibility exists of **electrical shock, electrocution or death.**

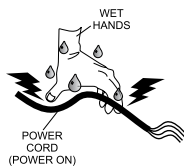

- Make sure power cables are securely connected to the generator's output receptacles. Incorrect connections may cause electrical shock and damage to the generator.

NOTICE

- **ALWAYS** make certain that proper power or extension cord has been selected for the job. See Cable Selection Chart in this manual.

Grounding Safety

DANGER

- **ALWAYS** make sure that electrical circuits are properly grounded to a suitable earth ground (ground rod) per the National Electrical Code (NEC) and local codes before operating generator. **Severe injury or death by electrocution** can result from operating an ungrounded generator.
- **NEVER** use gas piping as an electrical ground.

SAFETY INFORMATION

BATTERY SAFETY

DANGER

- **DO NOT** drop the battery. There is a possibility that the battery will explode.
- **DO NOT** expose the battery to open flames, sparks, cigarettes, etc. The battery contains combustible gases and liquids. If these gases and liquids come into contact with a flame or spark, an explosion could occur.



WARNING

- **ALWAYS** wear safety glasses when handling the battery to avoid eye irritation. The battery contains acids that can cause injury to the eyes and skin.
- Use well-insulated gloves when picking up the battery.
- **ALWAYS** keep the battery charged. If the battery is not charged, combustible gas will build up.
- **ALWAYS** recharge the battery in a well-ventilated environment to avoid the risk of a dangerous concentration of combustible gasses.
- If the battery liquid (dilute sulfuric acid) comes into contact with **clothing or skin**, rinse skin or clothing immediately with plenty of water.
- If the battery liquid (dilute sulfuric acid) comes into contact with **eyes**, rinse eyes immediately with plenty of water and contact the nearest doctor or hospital to seek medical attention.



CAUTION

- **ALWAYS** disconnect the **NEGATIVE battery terminal** before performing service on the generator.
- **ALWAYS** keep battery cables in good working condition. Repair or replace all worn cables.

ENVIRONMENTAL SAFETY

NOTICE

- Dispose of hazardous waste properly. Examples of potentially hazardous waste are used motor oil, fuel and fuel filters.
- **DO NOT** use food or plastic containers to dispose of hazardous waste.
- **DO NOT** pour waste, oil or fuel directly onto the ground, down a drain or into any water source.



SPECIFICATIONS

Table 1. Generator Specifications

Model	MQP20P	
Type	Rotating field, 4-pole, brushless, shunt excitation design	
Armature Connection	High Voltage Series	High Voltage Series (WYE)
Phase	Single	Three
Standby Output	20 kW (25 kVA)	20 kW (25 kVA)
Prime Output	17 kW (21.25 kVA)	17 kW (21.25 kVA)
Voltage	240 V	277Y/480V
Power Factor	1.0	0.8
Frequency	60 Hz	
Speed	1800 rpm	
Aux. AC Power	Single Phase, 60 Hz	

Table 2. Engine Specifications

Model	Perkins 404D-22 Tier 4	
Type	4 cycle, indirect injection	
No. of Cylinders	4 cylinders In-Line	
Bore x Stroke	3.30 in. x 3.93 in. (84 mm x 100 mm)	
Displacement	135 cu. in. (2.2 liters)	
Rated Output	32.6 HP at 1800 rpm	
Starting	Electric	
Coolant Capacity	0.9 gal. (3.6 liters)	
Lube Oil Capacity	2.8 gal. (10.6 liters)	
Fuel Type	#2 Diesel Fuel	
Fuel Tank Capacity	126 gal. (475 liters)	
Fuel Consumption	1.5 gal. (5.7 L)/hr at full load	1.2 gal. (4.5 L)/hr at 3/4 load
	0.8 gal. (3.0 L)/hr at 1/2 load	0.7 gal. (2.6 L)/hr at 1/4 load
Battery	12 VDC	

DIMENSIONS

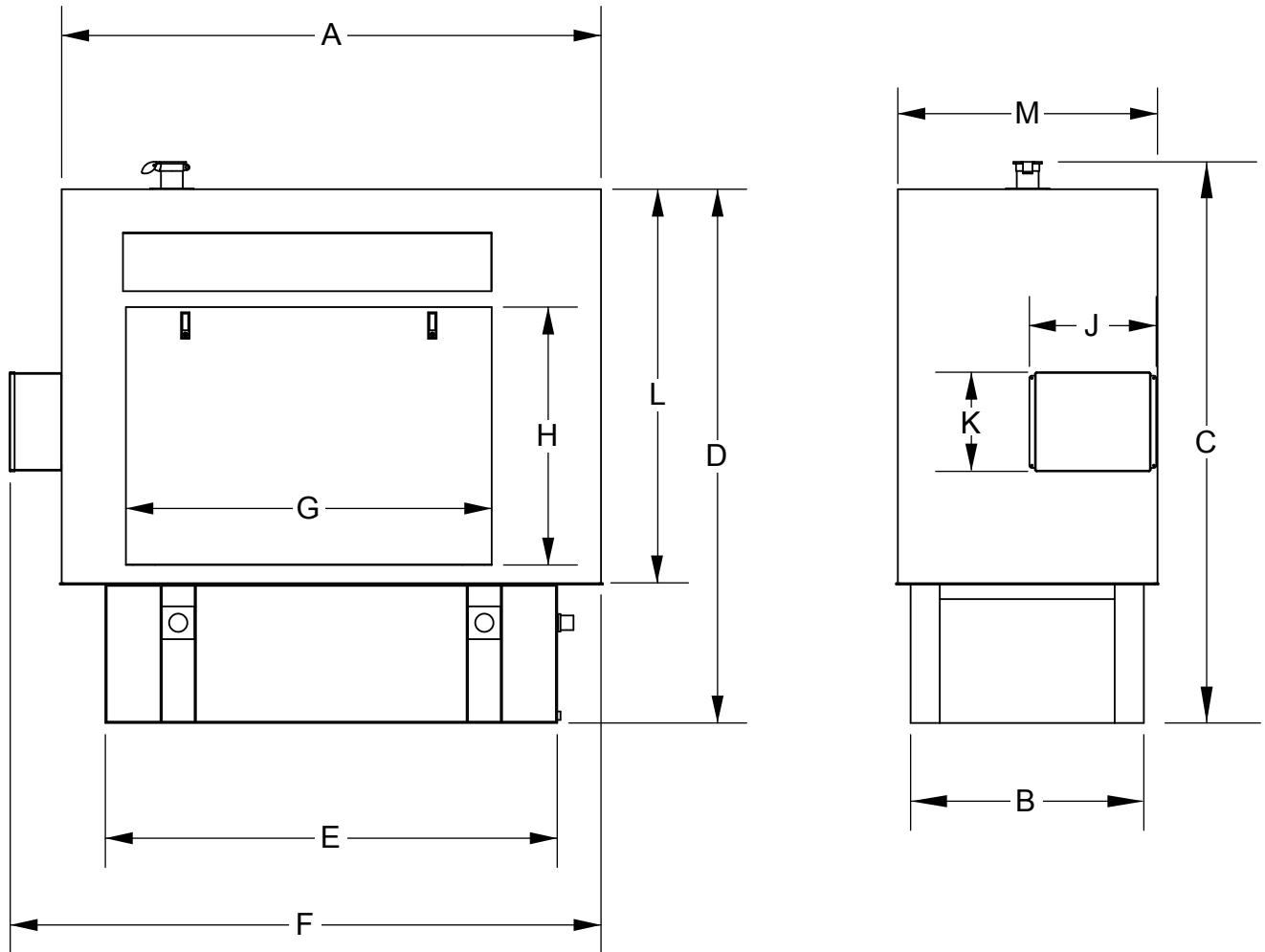

Figure 1. Dimensions

Table 3. Dimensions			
Reference Letter	Dimension in. (mm)	Reference Letter	Dimension in. (mm)
A	74 in. (1879.6 mm.)	G	50.19 in. (1274.8 mm.)
B	32 in. (812.8 mm.)	H	35.31 in. (896.9 mm.)
C	77 in. (1955.8 mm.)	J	17.5 in. (444.5 mm.)
D	73.06 in. (1855.7 mm.)	K	15 in. (381 mm.)
E	62 in. (1574.8 mm.)	L	54.06 in. (1373.1 mm.)
F	82.5 in. (2095.5 mm.)	M	35.5 in. (901.7 mm.)

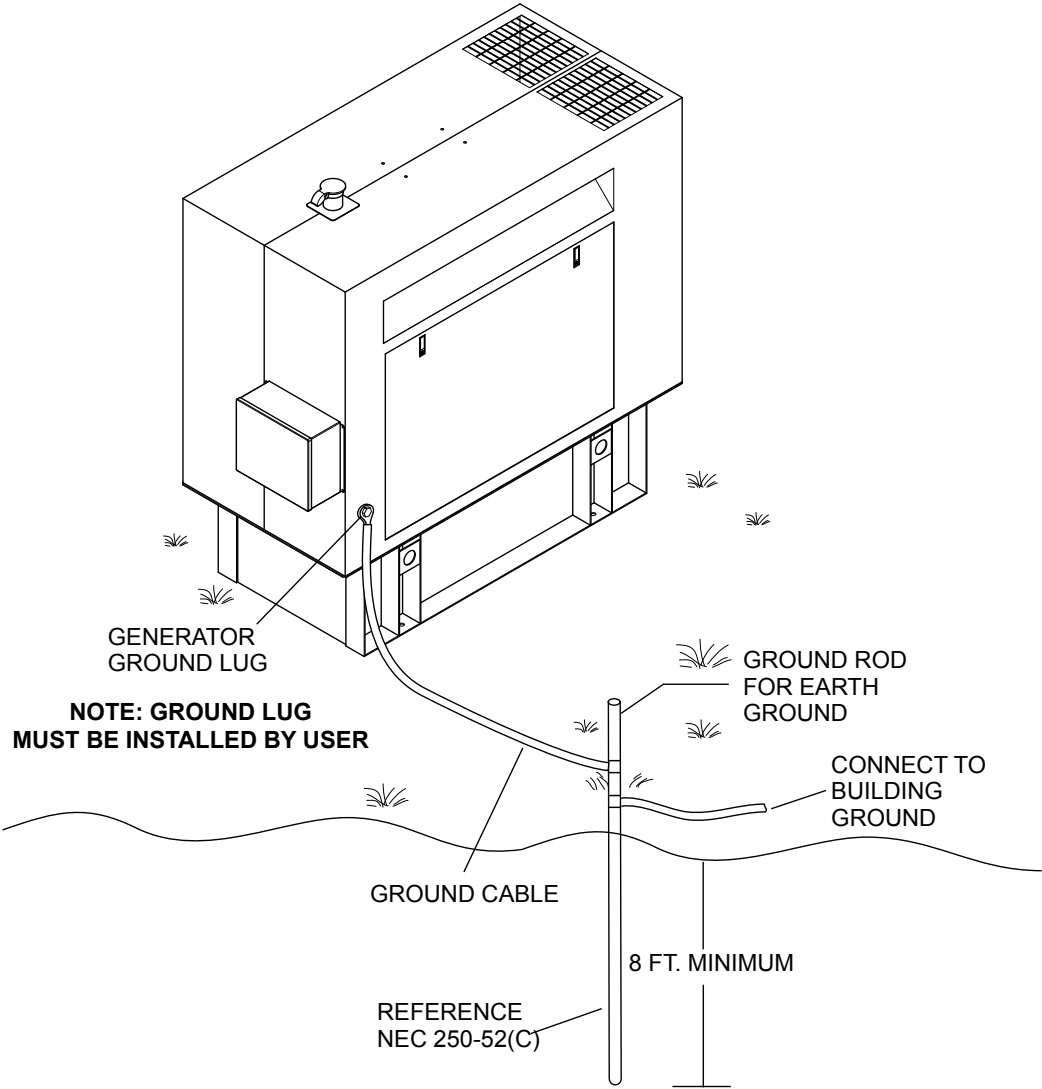

Figure 2. Typical Generator Grounding Application

OUTDOOR INSTALLATION

Install the generator in a area that is free of debris, bystanders, and overhead obstructions. Make sure the generator is on secure level ground so that it cannot slide or shift around. Also install the generator in a manner so that the exhaust will not be discharged in the direction of nearby homes.

The installation site must be relatively free from moisture and dust. All electrical equipment should be protected from excessive moisture. Failure to do so will result in deterioration of the insulation and will result in short circuits and grounding.

Foreign materials such as dust, sand, lint and abrasive materials have a tendency to cause excessive wear to engine and alternator parts.

CAUTION

Pay close attention to ventilation when operating the generator inside tunnels and caves. The engine exhaust contains noxious elements. Engine exhaust must be routed to a ventilated area.

INDOOR INSTALLATION

Exhaust gases from diesel engines are extremely poisonous. Whenever an engine is installed indoors the exhaust fumes must be vented to the outside. The engine should be installed at least two feet from any outside wall. Using an exhaust pipe which is too long or too small can cause excessive back pressure which will cause the engine to heat excessively and possibly burn the valves.

MOUNTING

The generator must be mounted on a solid foundation (such as concrete) and set firmly on the foundation to isolate vibration of the generator when it is running. The generator must sit at least 6 inches above the floor or grade level (in accordance to NFPA 110, Chapter 5-4.1).

GENERATOR GROUNDING

To guard against electrical shock and possible damage to the equipment, it is important to provide a good **EARTH** ground.

Article 250 (Grounding) of the National Electrical Code (NEC) provides guidelines for proper grounding and specifies that the cable ground shall be connected to the grounding system of the building as close to the point of cable entry as practical.

NEC articles 250-64(b) and 250-66 set the following grounding requirements:

1. Use one of the following wire types to connect the generator to earth ground.
 - a. Copper — 8 AWG (5.3 mm²)
 - b. Aluminum — 6 AWG (8.4 mm²)
2. When grounding the generator (Figure 2) connect the ground cable between the lock washer and the nut on the generator and tighten the nut fully. Connect the other end of the ground cable to earth ground.
3. NEC article 250-52(c) specifies that the earth ground rod should be buried a minimum of 8 ft. into the ground.

NOTICE

When connecting the generator to any building electrical system, **ALWAYS** consult a licensed electrician.

GENERAL INFORMATION

GENERATOR

This generator (Figure 3) is a high-quality, reliable, backup power source used by telecommunications companies to keep their networks connected.

CONTROL PANEL (MEC 20™ Digital Controller)

■ AC Metering Display

- Voltage/Amperage / Frequency
- Generator Phase Voltage / Current
- Generator Frequency

■ Engine Information Display

- Engine Temperature / Oil Pressure (psi)
- Battery Voltage (DC) / Tachometer
- Hourmeter

■ Minor Fault Warning Display

- Switch Not In Auto
- Low Fuel Level
- Low Oil Pressure Alarm
- Low Engine Temperature
- High Engine Temperature Alarm
- Low Battery Voltage
- High Battery Voltage
- Weak Battery Condition
- Battery Charger Input Fail
- Undervoltage
- Over / Underfrequency
- Overcurrent

■ Major Fault Shutdown Display

- Overvoltage
- Emergency Stop
- Loss Of Speed
- Overcrank
- Overspeed
- Low Oil Pressure
- High Engine Temperature
- Low Coolant Level
- Spare Programmable Digital Faults

■ Switches And Operating Controls

- Run / Off / Auto / Load Test Buttons
- Decrement / Increment / Previous (Exit) /Next (Enter) Program Buttons
- Emergency Stop Button
- Audible Alarm Horn – 80 dB(A) at 2 ft.
- Alarm Horn Silence Button
- Lamp Test Button
- Fault Reset Function
- RJ45 Remote Communications, External Expansion Module Ports

■ Timer Countdown Display

- Engine Start Delay
- Oil Bypass
- Overcrank
- Cycle Crank
- Starter Re-engage Delay
- Bypass Delay

■ Control LED Indicators

- Switch Position (Run,Off,Auto,Test)
- Common Alarm (Minor Fault)
- Common Shutdown (Major Fault)
- Generator Ready (When in Auto)
- Speed Signal
- Emergency Stop

■ Diagnostic LED Indicators:

- Run Output Energized
- Crank Output Energized
- Remote Start Signal Initiated
- Common Fail Output Energized
- Watchdog - CPU Running
- Programmable Output Contacts

CAMLOK OUTLET BOX PANEL

The “Camlok Panel” is provided with the following receptacles:

- Ground (GRND.) - Green
- Neutral (NEUT.) - White
- LEG 1 - Black
- LEG 2 - Red
- LEG 3 - Blue

GENERAL INFORMATION

PRINCIPLE OF OPERATION

This generator is a brushless, self-excited, externally voltage regulated, synchronous AC generator. The generator is made up of six major components: main stator (armature), main rotor (field), exciter stator (field), exciter rotor (armature), rectifier assembly, and voltage regulator.

The generator's exciter consists of a stationary field and a rotating armature. The stationary field (exciter stator) is designed to be the primary source of the generator's residual magnetism. This residual magnetism allows the exciter rotor (armature) to produce AC voltage even when the exciter stator (field) is not powered. This AC voltage is rectified to DC by the rotating rectifier assembly and fed directly to the main rotor (field). As the generator shaft continues to rotate, the main rotor (field) induces a voltage into the generator's main stator (armature). At rated speed, the main stator's voltage produced by the residual magnetism of the exciter allows the automatic voltage regulator to function.

The regulator provides voltage to the exciter resulting in a build-up of generator terminal voltage. This system of using residual magnetism eliminates the need for a special field flashing circuit in the regulator. After the generator has established the initial residual voltage, the regulator provides a controlled DC field voltage to the exciter stator resulting in a controlled generator terminal voltage.

VOLTAGE REGULATION

In the standard configuration (shunt excited), the automatic voltage regulator receives both its input power and voltage sensing from the generator's output terminals. The regulator automatically monitors the generator's output voltage against an internal reference set point and provides the necessary DC output voltage to the exciter field required to maintain constant generator terminal voltage. The generator's terminal voltage is changed by adjusting the regulator's reference set point.

ENGINE

This standby generator incorporates a Perkins 404D-22 Tier 4 diesel engine. This engine is designed to meet every performance requirement for the generator. Refer to Table 2 for engine specifications.

In keeping with Multiquip's policy of constantly improving its products, the specifications quoted herein are subject to change without prior notice.

ELECTRONIC GOVERNOR SYSTEM

The electronic governor system controls the RPMs of the engine. When the engine demand increases or decreases, the governor system regulates the frequency variation to $\pm 0.25\%$.

MAJOR COMPONENTS

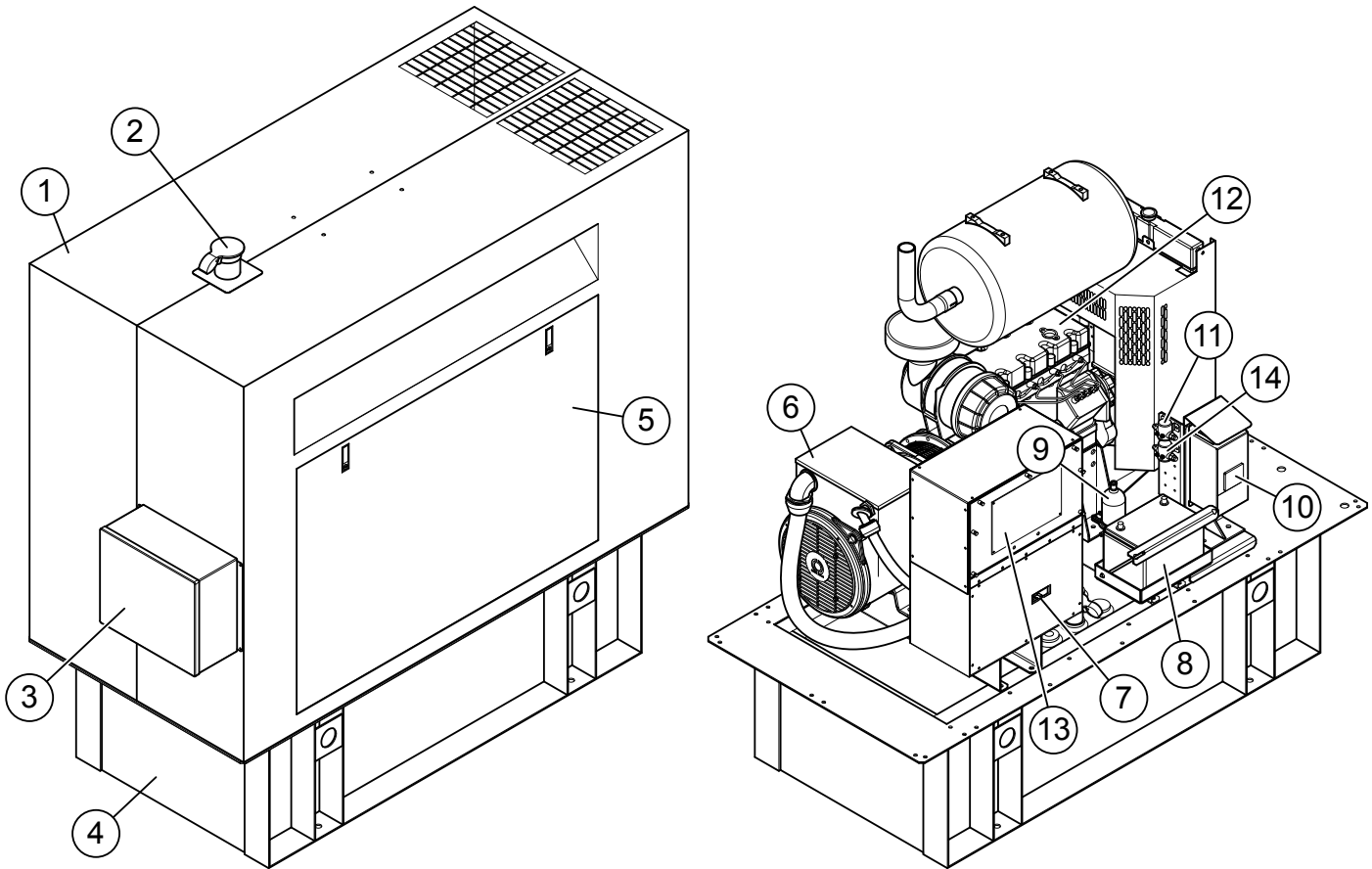

Figure 3. Major Components

Table 4. Generator Major Components

ITEM NO.	DESCRIPTION
1	Housing Assembly
2	Exhaust Rain Cap
3	Camlok Connector Box Assembly
4	Fuel System Sub Base Assembly
5	Door Assembly
6	Generator Assembly
7	Circuit Breaker Assembly
8	Battery Assembly
9	Jacket Water Heater Assembly
10	Battery Charger Assembly
11	Starter Solenoid
12	Engine Assembly
13	Controller Assembly
14	Glow Plug Relay

BASIC ENGINE COMPONENTS

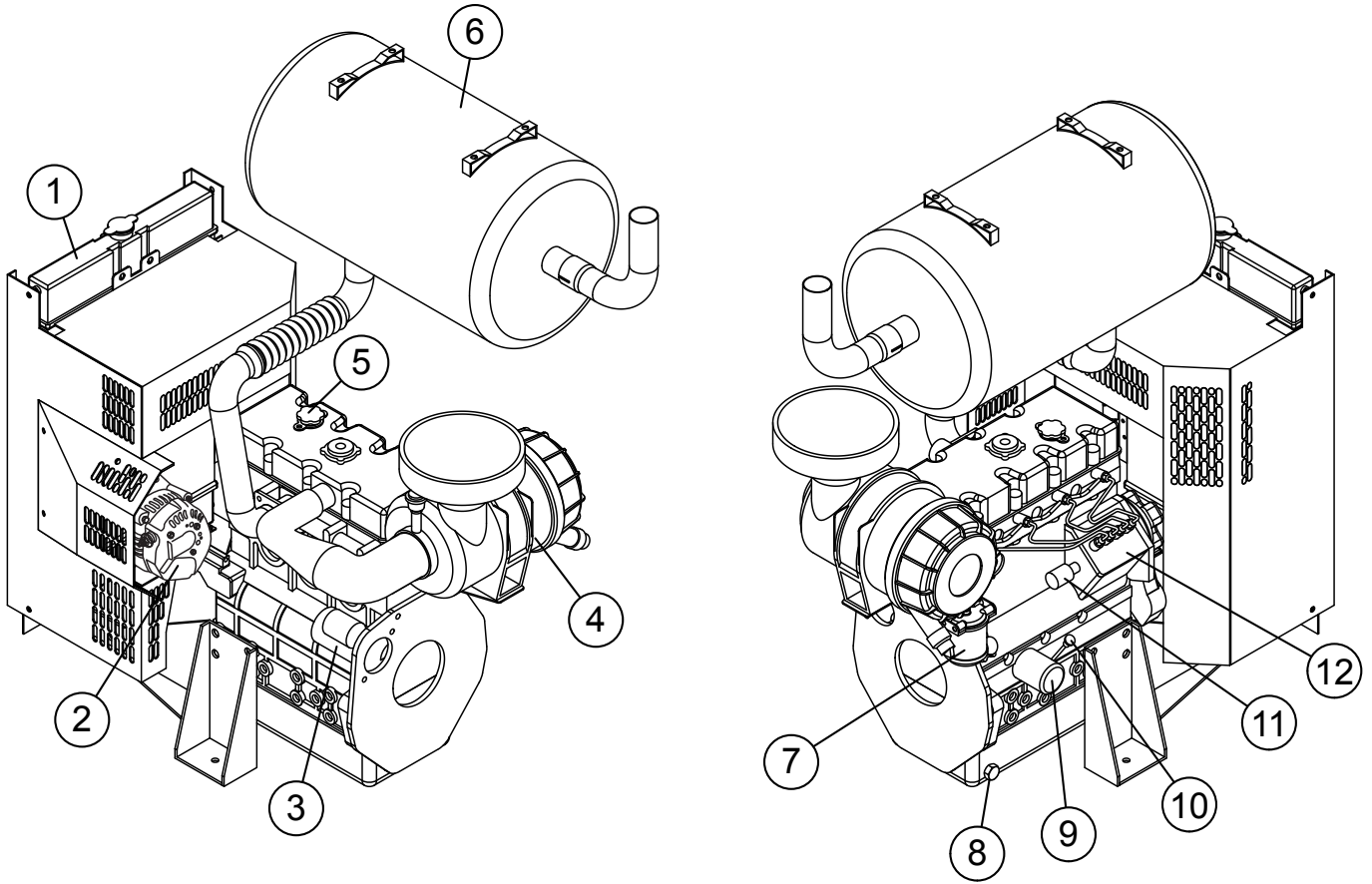

Figure 4. Basic Engine Components

Table 5. Basic Engine Components	
ITEM NO.	DESCRIPTION
1	Radiator
2	Alternator
3	Starter
4	Air Filter
5	Oil Filler Cap
6	Muffler
7	Fuel Filter
8	Oil Drain Plug
9	Oil Filter
10	Oil Dipstick
11	Governor Actuator
12	Fuel Injection Pump

DIGITAL CONTROLLER PANEL

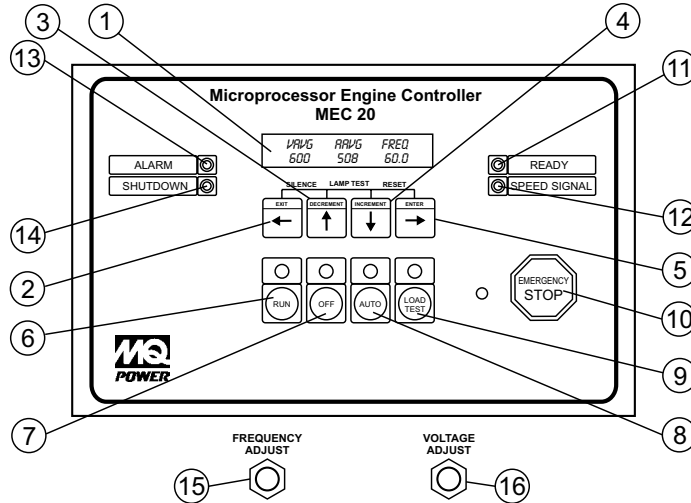

Figure 5. Digital Controller Components

1. **Liquid Crystal Display** — Displays voltage, amperage, frequency, engine information, fault warnings, and other generator and engine information.
2. **EXIT Pushbutton** — Press button to scroll backwards through the status menus or programming prompts. Press and hold for approximately 2 seconds to exit programming menu when in the programming mode.
3. **DECREMENT Pushbutton** — Press button to change a programming value while in the programming mode. Press and hold this button to decrease value continuously and release when desired value is displayed. NOTE: The longer the button is held down, the faster the value will decrease.
4. **INCREMENT Pushbutton** — Press button to change a programming value while in the programming mode or to select a desired programming menu loop. Press and hold this button to increase value continuously and release when desired value is displayed. NOTE: The longer the button is held down, the faster the value will increase.
5. **ENTER Pushbutton** — Press button to scroll through the status menus or programming prompts. This button is used to enter a programming mode as well as accepting changed programming values. NOTE: The longer the button is held down, the faster the next menu prompt will appear.
6. **RUN Pushbutton and LED** — Press button to initiate a manual start signal to the generator. The LED will light when in RUN mode.
7. **OFF Pushbutton and LED** — Press button to initiate a stop signal to the generator. The LED will light when in OFF mode.
8. **AUTO Pushbutton and LED** — Press button to initiate automatic operation of the generator. The LED will light when in AUTO mode.
9. **LOAD TEST Pushbutton and LED** — Press button to initiate load test of the generator when connected to an associated transfer switch. The LED will light when in LOAD TEST mode.
10. **EMERGENCY STOP Pushbutton and LED** — Press button to initiate an emergency stop signal to the generator.
11. **READY LED** — Lights when the generator is set for automatic operation and no shutdown or alarm faults have been activated.
12. **SPEED SIGNAL LED** — Lights when the engine speed signal is detected.
13. **ALARM LED** — Lights when any pre-programmed alarm fault has been activated.
14. **SHUTDOWN LED** — Flashes when any pre-programmed shutdown fault has been activated.
15. **FREQUENCY ADJUST** — This screwdriver adjustable potentiometer is used to fine tune the roll-off frequency from 54 to 61 Hz.
16. **VOLTAGE ADJUST** — This screwdriver adjustable potentiometer is used to fine tune the generator output voltage.

CONNECTOR OUTLET BOX AND MAIN CIRCUIT BREAKER

OUTLET CONNECTORS

The Camlok outlet box has the following connectors

- Ground (GRND.)
- Neutral (NEUT.)
- LEG 1, LEG 2, LEG 3 (3-phase only)

MAIN CIRCUIT BREAKER

The generator is equipped with a three-pole, 100 or 30 amp, (single/three phase) circuit breaker to protect the generator from overload.

See Figure 6 for connections.

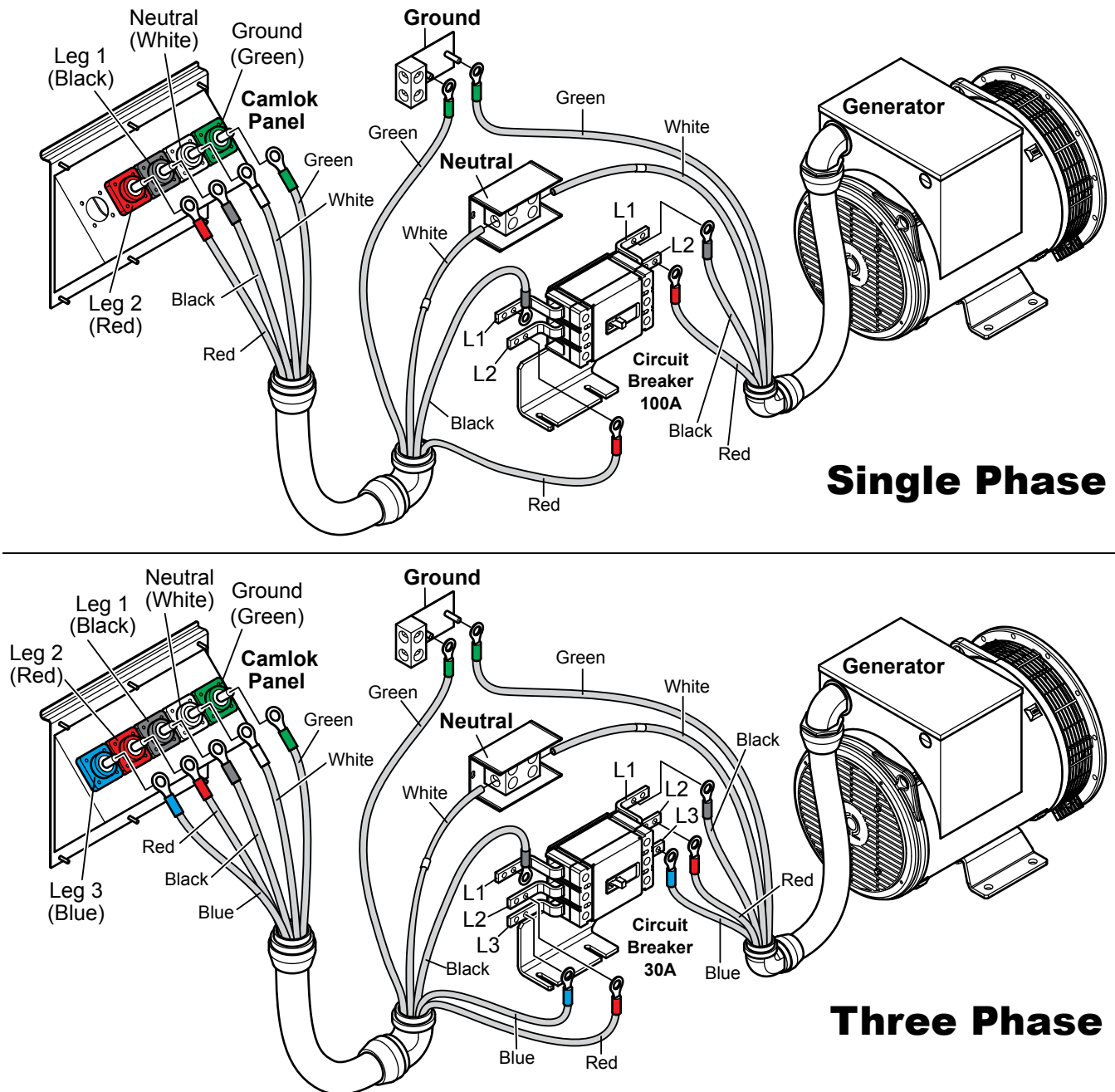

Figure 6. Camlok Box and Circuit Breaker Connections

LOAD APPLICATION/GENERATOR OUTPUT

SINGLE PHASE LOAD

Always be sure to check the nameplate on the generator and equipment to insure the wattage, amperage, frequency, and voltage requirements are satisfactorily supplied by the generator for operating the equipment.

Generally, the wattage listed on the nameplate of the equipment is its rated output. Equipment may require 130—150% more wattage than the rating on the nameplate, as the wattage is influenced by the efficiency, power factor and starting system of the equipment.

NOTICE

If wattage is not given on the equipment's name plate, approximate wattage may be determined by multiplying nameplate voltage by the nameplate amperage.

$$\text{WATTS} = \text{VOLTAGE} \times \text{AMPERAGE}$$

The power factor of this generator is 1.0. See Table 6 below when connecting loads.

Table 6. Power Factor By Load

Type of Load	Power Factor
Single-phase induction motors	0.4-0.75
Electric heaters, incandescent lamps	1.0
Fluorescent lamps, mercury lamps	0.4-0.9
Electronic devices, communication equipment	1.0
Common power tools	0.8

Table 7. Cable Selection (60 Hz, Single Phase Operation)

Current in Amperes	Load in Watts		Maximum Allowable Cable Length			
	At 100 Volts	At 200 Volts	#10 Wire	#12 Wire	#14 Wire	#16 Wire
2.5	300	600	1000 ft.	600 ft.	375 ft.	250 ft.
5	600	1200	500 ft.	300 ft.	200 ft.	125 ft.
7.5	900	1800	350 ft.	200 ft.	125 ft.	100 ft.
10	1200	2400	250 ft.	150 ft.	100 ft.	
15	1800	3600	150 ft.	100 ft.	65 ft.	
20	2400	4800	125 ft.	75 ft.	50 ft.	

CAUTION: Equipment damage can result from low voltage

NOTICE

Motors and motor-driven equipment draw much greater current for starting than during operation.

An inadequate size connecting cable which cannot carry the required load can cause a voltage drop which can burn out the appliance or tool and overheat the cable. Refer to Table 7 to select the correct cable size.

- When connecting a resistance load such as an incandescent lamp or electric heater, a capacity of up to the generator's rated output (kW) can be used.
- When connecting a fluorescent or mercury lamp, a capacity of up to the generator's rated output (kW) multiplied by 0.6 can be used.
- When connecting an electric drill or other power tools, pay close attention to the required starting current capacity.

When connecting ordinary power tools, a capacity of up to the generator's rated output (kW) multiplied by 0.8 can be used.

DANGER

Before connecting this generator to any building's electrical system, a **licensed electrician** must install a **transfer switch**. Serious damage to the building's electrical system may occur without this transfer switch.

Generator Amperage

Table 8 shows the **maximum** amps the generator can provide. **DO NOT** exceed the maximum amps as listed.

Table 8. Generator Maximum Amps

Rated Voltage	Maximum Amps
1Ø 120 Volt	83 X 2 amps (4 wire)
1Ø 240 Volt	83 amps (4 wire)

MAIN CIRCUIT BREAKER

The generator is equipped with a 3-pole, 100-amp circuit breaker to protect it from overload. Make sure that the circuit breaker is in the OFF position prior to starting the engine.

LUBRICATION OIL

Fill the engine crankcase with lubricating oil through the filler hole, but **DO NOT** overfill. Make sure the generator is level and verify that the oil level is maintained between the two notches (Figure 7) on the dipstick. See Table 9 for proper selection of engine oil.

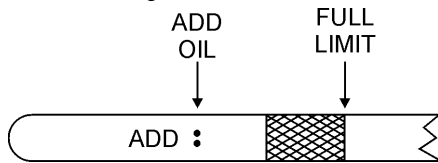

Figure 7. Engine Oil Dipstick

When checking the engine oil, be sure to check if the oil is clean. If the oil is not clean, drain the oil by removing the oil drain plug, and refill with the specified amount of oil as outlined in the **Perkins Engine Owner's Manual**. Oil should be warm before draining.

Other types of motor oils may be substituted if they meet the following requirements:

- API Service Classification CC/SC
- API Service Classification CC/SD
- API Service Classification CC/SE
- API Service Classification CC/SF

Table 9. Recommended Motor Oil	
OIL: SAE	
°F	°C
122	50
104	40
86	30
68	20
50	10
32	0
-14	-10
-4	-20
-22	-30
-40	-40

FUEL CHECK

! DANGER



Fuel spillage on a **hot** engine can cause a **fire** or **explosion**. If fuel spillage occurs, wipe up the spilled fuel completely to prevent fire hazards. **NEVER** smoke around or near the generator.

Refilling the Fuel System

! CAUTION

ONLY properly trained personnel who have read and understood this section should refill the fuel tank system.

This generator has a fuel tank located in the sub base assembly frame (Figure 3). **ALWAYS** fill the fuel tank with clean fresh **#2 diesel fuel**. **DO NOT** fill the fuel tank beyond its capacity.

Pay attention to the fuel tank capacity when replenishing fuel. The fuel tank cap must be closed tightly after filling. Handle fuel in a safe container. If the container does not have a spout, use a funnel. Wipe up any spilled fuel immediately.

Refueling Procedure:

! WARNING



Diesel fuel and its vapors are dangerous to your health and the surrounding environment. Avoid skin contact and/or inhaling fumes.

! CAUTION

ALWAYS make sure generator is on firm level ground before refueling to prevent spilling and maximize the amount of fuel that can be pumped into the tank.

INSPECTION/SETUP

1. Place the generator level with the ground. Failure to do so will cause fuel to spill from the tank before reaching full capacity (Figure 8).

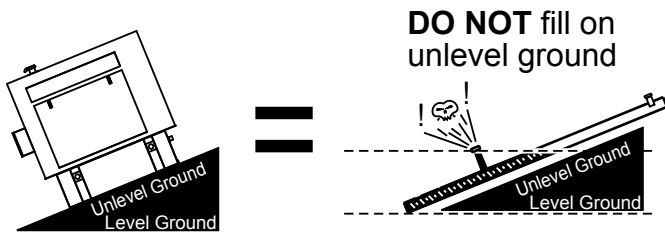

Figure 8. Only Fill on Level Ground

NOTICE

ONLY use #2 diesel fuel when refueling.

2. Unlatch and remove the cabinet door of the generator. Remove fuel cap and fill tank (Figure 9).

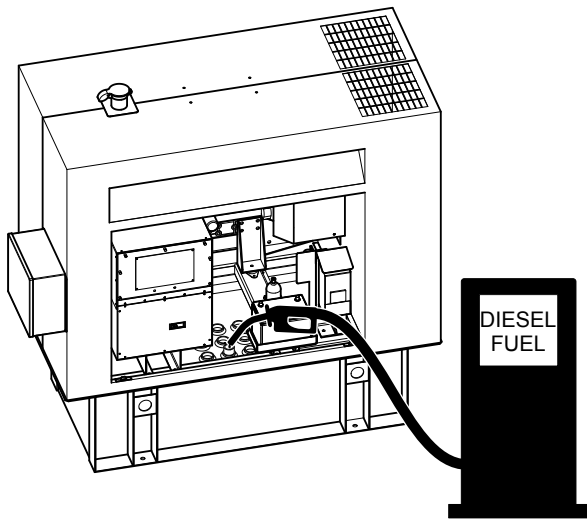

Figure 9. Fueling the Generator

3. Monitor the fuel gauge while filling fuel tank. Stop filling when the fuel gauge indicates full (Figure 10). **DO NOT** wait for fuel to rise in filler neck.

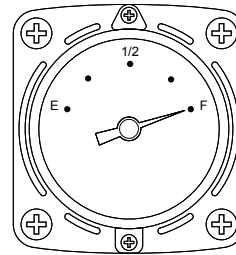

Figure 10. Full Fuel Tank

CAUTION

DO NOT OVERFILL fuel system. Leave room for fuel expansion. Fuel expands when heated (Figure 11).

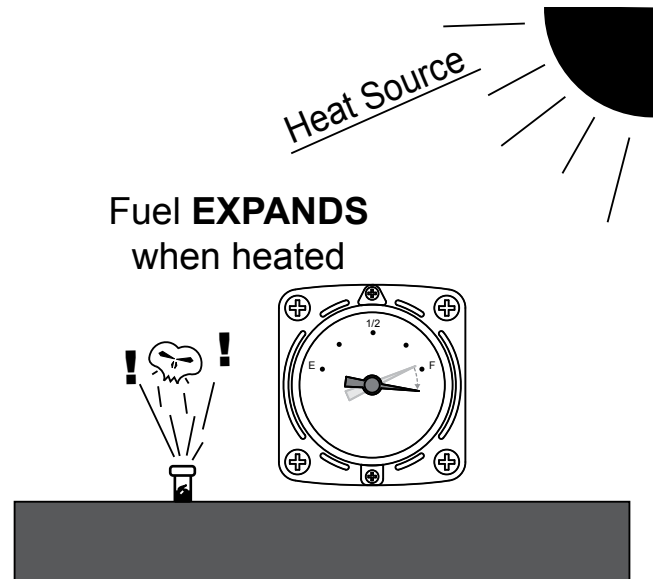



Figure 11. Fuel Expansion

COOLANT (ANTIFREEZE/SUMMER COOLANT)

Perkins recommends antifreeze/summer coolant, for use in their engines, which can be purchased in concentrate (and mixed with 50% demineralized water) or pre-diluted. See the **Perkins Engine Owner's Manual** for further details.

WARNING



If adding coolant/antifreeze mix to the radiator, **do not** remove the radiator cap until the unit has completely cooled. The possibility of **hot** coolant exists which can cause severe burns.

The engine coolant capacity is 3.8 quarts (3.6 liters).

OPERATION IN FREEZING WEATHER

When operating in freezing weather, be certain the proper amount of antifreeze (Table 10) has been added.

Table 10. Anti-Freeze Operating Temperatures				
Vol % Anti-Freeze	Freezing Point		Boiling Point	
	°C	°F	°C	°F
50	-37	-34	108	226

NOTICE

When the antifreeze is mixed with water, the antifreeze mixing ratio **must be** less than 50%.

CLEANING THE RADIATOR

The engine may overheat if the radiator fins become overloaded with dust or debris. Periodically clean the radiator fins with compressed air. Cleaning inside the machine is dangerous, so clean only with the engine turned off and the **negative** battery terminal disconnected.

AIR CLEANER

Periodic cleaning/replacement is necessary. Inspect it in accordance with the **Perkins Engine Owner's Manual**.

FAN BELT TENSION

A slack fan belt may contribute to overheating, or to insufficient charging of the battery. Inspect the fan belt for damage and wear and adjust it in accordance with the **Perkins Engine Owner's Manual**.

The fan belt tension is proper if the fan belt bends 10 to 15 mm (Figure 12) when depressed with the thumb as shown below.

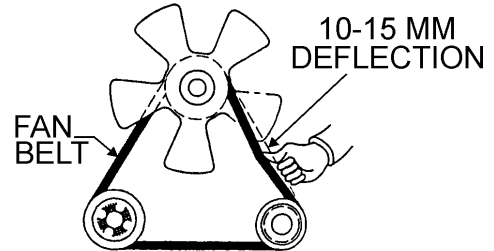



Figure 12. Fan Belt Tension

CAUTION



NEVER place hands near the belts or fan while the generator is running.

BATTERY

This unit is of negative ground. **DO NOT** connect in reverse. Always maintain battery fluid level between the specified marks. **DO NOT** over fill. Battery life will be shortened if the fluid level is not properly maintained. Add only distilled water when replenishment is necessary.

Check to see whether the battery cables are loose. Poor contact may result in poor starting or malfunction. **Always** keep the terminals firmly tightened. Coat the terminals with an approved battery terminal treatment compound. Replace battery with only recommended type battery.

The battery is sufficiently charged if the specific gravity of the battery fluid is 1.28 (at 68° F). If the specific gravity should fall to 1.245 or lower, the battery is dead and needs to be recharged or replaced.

Before charging the battery with an external electric source, be sure to disconnect the battery cables.

Battery Cable Installation

ALWAYS make sure that the battery cables (Figure 13) are properly connected to the battery terminals as shown below.

CAUTION

ALWAYS disconnect the negative terminal **FIRST** and reconnect negative terminal **LAST**.

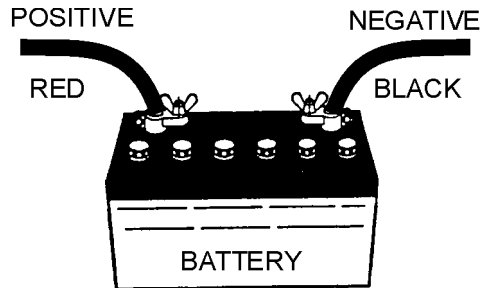

Figure 13. Battery Connections

When connecting the battery do the following:

1. Place a small amount of battery terminal treatment compound around both battery terminals. This will ensure a good connection and will help prevent corrosion around the battery terminals.
2. Connect the **red cable** to the positive terminal of the battery and the **black cable** to the negative terminal of the battery.

NOTICE

If the battery cable is connected incorrectly, electrical damage to the generator will occur. Pay close attention to the polarity when connecting the battery.

CAUTION

Inadequate battery connections may cause poor starting of the generator, and create other malfunctions.

ALTERNATOR

The polarity of the alternator is negative grounding type. When an inverted circuit connection takes place, the circuit will short instantaneously resulting in alternator failure.

DO NOT put water directly on the alternator. Water in the alternator can cause corrosion and damage.

WIRING

Inspect the generator for bad, worn electrical wiring or connections. If any wiring or connections are exposed (insulation missing), replace wiring immediately.

PIPING AND HOSE CONNECTION

Inspect all piping, oil hose, and fuel hose connections for wear and tightness. Tighten all hose clamps and check hoses for leaks.

If any hose (**fuel or oil**) lines are defective, replace them immediately.

BEFORE STARTING

CAUTION

The engine's exhaust contains harmful emissions. **ALWAYS** have adequate ventilation when operating. Direct exhaust away from nearby personnel.

WARNING

NEVER manually start the engine with the **main** circuit breaker in the **ON** position.

1. Place the main circuit breaker (Figure 14) in the **OFF** position prior to starting the engine.

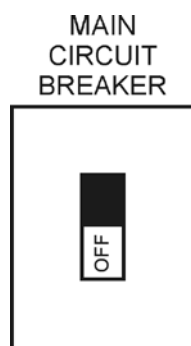

Figure 14. Main Circuit Breaker (OFF)

2. Connect the load to the receptacles on the Camlok outlet box. See Figure 6.
3. Tighten terminal nuts securely to prevent load wires from slipping out.

STARTING (MANUAL)

1. Press the **RUN** button (Figure 15) on the controller to start the engine.

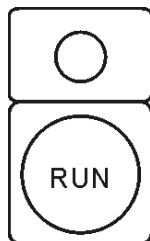

Figure 15. Run Button

2. Once the engine starts, let the engine run for 1-2 minutes. At temperatures below freezing, this time period must be extended to 2-4 minutes.

3. Listen for any abnormal noises. If any abnormalities exist, shut down the engine and correct the problem.
4. Using the controller display, verify that the no-load frequency and speed is approximately 62.5 Hz (1875 rpm).
5. Place the main circuit breaker (Figure 16) to the **ON** position. Voltage is now available at the receptacles.

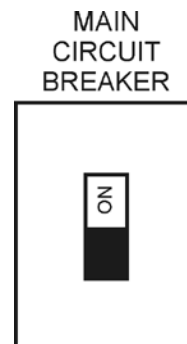

Figure 16. Main Circuit Breaker (ON)

STARTING (AUTO MODE)

DANGER



Before connecting the generator to a building's electrical system, a **licensed electrician** must install a **transfer switch**. Serious damage to the building's electrical system may occur without a transfer switch.

CAUTION

When connecting the generator to an automatic transfer switch, **ALWAYS** have power applied to the generator's internal battery charger. This will ensure that the engine will not fail due to a dead battery.

WARNING

When running the generator in the **AUTO** mode, the generator can start up at any time without warning. **NEVER** attempt to perform any maintenance when the generator is in the **AUTO** mode.

NOTICE

When the generator is placed in the **AUTO** mode, the engine glow plugs will be warmed and the engine will start automatically.

1. Press the **AUTO** button (Figure 17) on the digital controller to place the generator in the auto mode. This mode allows the controller to monitor the remote-start contacts.

Closure of the remote-start contacts will begin engine cranking. When the contacts are opened, cranking will stop or if the engine is running, engine will stop.

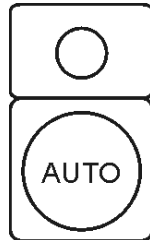

Figure 17. Auto Button

NOTICE

If the generator is to be connected to a building's AC power source via an automatic transfer switch (ATS), press the **AUTO** button (Figure 17) to place the generator in auto mode.

In this position, should an outage occur, the automatic transfer switch (ATS) will start the generator automatically through the generator remote-start contacts connected to the automatic transfer switch start contacts.

Refer to your ATS installation manual on how to connect the ATS to the generator remote-start contacts.

CLOSING THE ENCLOSURE DOOR

1. Close the engine enclosure door once the generator has started or set to auto start (Figure 18).

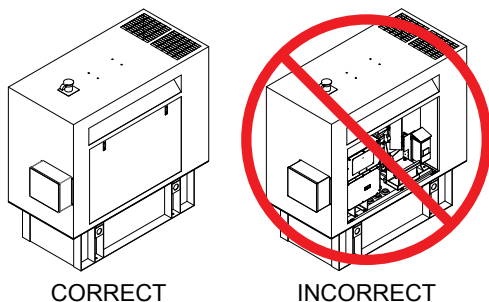

Figure 18. Engine Enclosure Door

2. If access to the controls or other components is necessary while the engine is running, make sure the door is not left open for an extended period of time.

NORMAL SHUTDOWN PROCEDURE

To shutdown the generator, use the following procedure:

WARNING

NEVER stop the engine suddenly except in an emergency.

1. Place the main circuit breaker (Figure 19) in the **OFF** position.

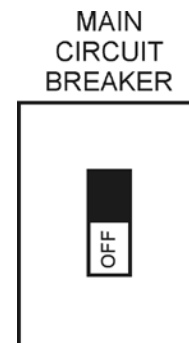

Figure 19. Main Circuit Breaker (OFF)

2. Let the engine cool by running it at low speed for 3-5 minutes with no load applied.
3. Press the **OFF** button (Figure 20) on the digital controller to shutdown the engine.

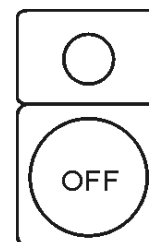

Figure 20. OFF Button

EMERGENCY SHUTDOWN PROCEDURE

1. Place the main circuit breaker (Figure 19) in the **OFF** position.
2. Press the **OFF** button (Figure 20) on the digital controller to shutdown the engine.

JACKET WATER HEATER AND INTERNAL BATTERY CHARGER

This generator is equipped with a jacket water heater and an internal battery charger. They are provided with electric cords to connect to a commercial power source.

These units will **ONLY** function when commercial power has been supplied to them (Figure 21). When using extension cords, refer to Table 7 for the correct size and length.

The battery charger should always be connected to a commercial power source to ensure that the battery does not get discharged.

When using the generator in **hot** climates there is no need to apply power to jacket water heater. However, if the generator will be used in **cold** climates, it is best to apply power to the jacket water heater at all times.

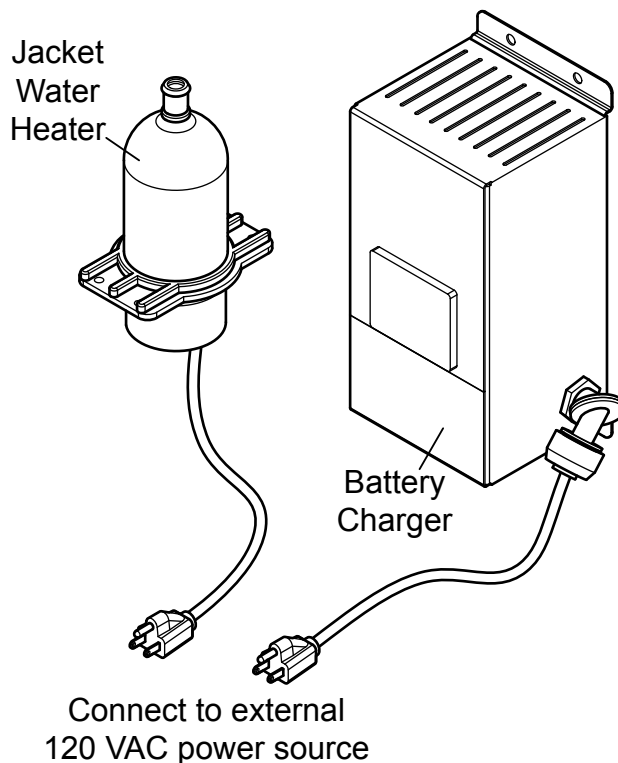

Figure 21. Battery Charger and Jacket Water Heater Power Connections

PROTECTIVE DEVICES

Protection devices and emergency stop devices are provided for protection of the generator against trouble during operation. The alarm LED on the digital controller lights or flashes when a fault is detected.

When a major fault is detected, such as low oil pressure, high water temperature, and overspeed, the engine automatically shuts down. Check the display for the fault and correct the problem.

For minor faults, the engine will continue working. Stop the engine and remedy the cause of the problem.

Before inspecting or troubleshooting the generator, press the **OFF** button on the Digital Controller. Place all circuit breakers in the **OFF** position and allow sufficient time for adequate cooling.

After automatic shutdown, always inspect the generator and eliminate any problems that might have caused the shutdown before attempting to restart the generator.

When ready to restart the generator, make sure all circuit breakers are **OFF**. Also check and make sure that the **OFF** button on the Digital Controller has been pressed to clear the system and that the OFF LED on the Digital Controller is **RED**. Restart the generator as outlined in the Startup section of this manual.

Refer to the MEC20 Microprocessor Engine/Generator Controller Manual for detailed information of faults and display information.

TRANSPORTING

When transporting the generator in a flatbed truck:

1. Make sure that the fuel tank is empty.
2. Secure the generator with chains through the lifting eyes on the fuel tank. See Figure 22.

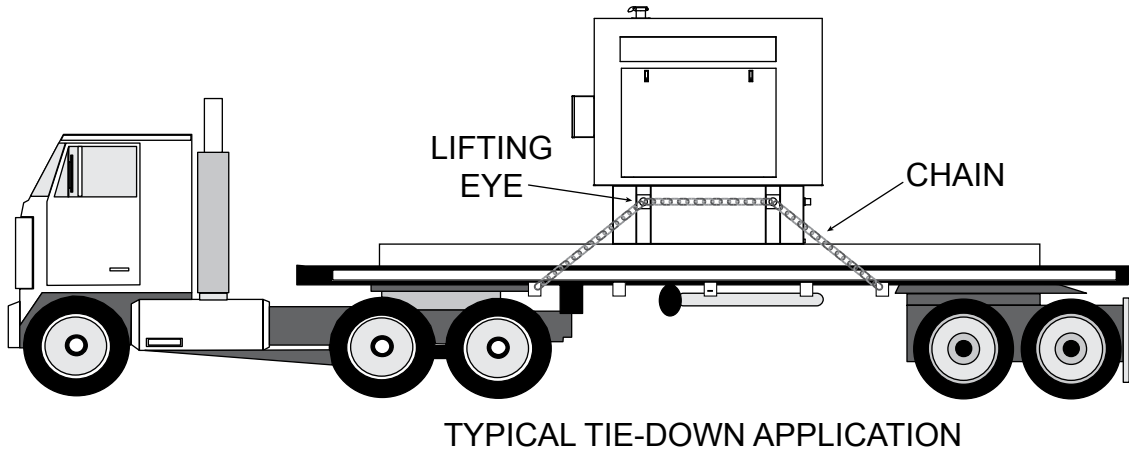

Figure 22. Transporting On A Flatbed Truck

Table 11. Inspection/Maintenance		10 Hrs DAILY	250 Hrs	500 Hrs	1000 Hrs
Engine	Check Engine Fluid Levels	X			
	Check Air Cleaner	X			
	Check Battery Acid Level	X			
	Check Fan Belt Condition	X			
	Check for Leaks	X			
	Check for Loose Parts	X			
	Replace Engine Oil and Filter * ¹		X		
	Clean Air Filter		X		
	Check Fuel Filter/Water Separator Bowl	X			
	Clean Unit, Inside and Outside		X		
	Change Fuel Filter			X	
	Clean Radiator and Check Coolant Level* ²			X	
	Replace Air Filter Element * ³			X	
	Check all Hoses and Clamps * ⁴				X
	Clean Inside of Fuel Tank				X
Generator	Measure Insulation Resistance Over 3M ohms		X		
	Check Rotor Rear Support Bearing			X	
<p>*¹ Replace engine oil and filter at 100 hours, first time only.</p> <p>*² Add "Supplemental Coolant Additives (SCA's)" to recharge the engine coolant.</p> <p>*³ Replace primary air filter element when restriction indicator shows a vacuum of 625 mm (25 in. H₂O).</p> <p>*⁴ If blowby hose needs to be replaced, ensure that the slope of the blowby hose is at least a 1/2 inch per foot, with no sags or dips that could collect moisture and/or oil.</p>					

GENERAL INSPECTION

Prior to each use, the generator should be cleaned and inspected for deficiencies. Check for loose, missing or damaged nuts, bolts, and other fasteners. Also check for fuel, oil, and coolant leaks. Use Table 11 as a general maintenance guideline. For engine maintenance, refer to the engine instruction manual.

AIR FILTER

Every 250 hours: Remove air filter element (Figure 23) and clean the filter element with low pressure compressed air. Air pressure must not exceed 30 psi (207 kPa). The filter can be cleaned and reused for up to six times if properly cleaned. Replace air filter if rips or tears are detected while cleaning.

Air Filter Dust Indicator

The air filter indicator (Figure 23) is attached to the air filter.

When the air filter element is clogged, air intake restriction becomes greater and the air filter indicator signal shows **RED**. When indicator is red, replace filter immediately. After changing the air filter, press the air filter indicator button to reset.

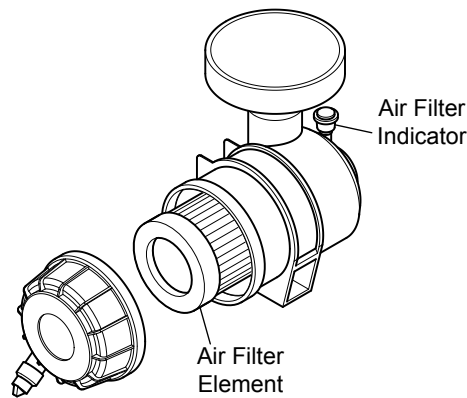

Figure 23. Air Filter/Indicator

NOTICE

The air filter should be changed more frequently in dusty operating conditions.

If the engine is operating in very dusty or dry grass conditions, a clogged air cleaner will result. This can lead to a loss of power, excessive carbon buildup in the combustion chamber and high fuel consumption. Change air cleaner more frequently if these conditions exist.

FUEL ADDITION

Add diesel fuel (the grade may vary according to season and locations).

Removing Water from the Fuel Tank

After prolonged use, water and other impurities accumulate in the bottom of the tank. Occasionally inspect the fuel tank for water contamination and drain the contents if necessary.

During cold weather, the more empty volume inside the tank, the easier it is for water to condense. This can be reduced by keeping the tank full with diesel fuel.

Cleaning Inside the Fuel Tank

If necessary, drain the fuel inside the fuel tank completely. Using a spray washer (Figure 24) wash out any deposits or debris that have accumulated inside the fuel tank.

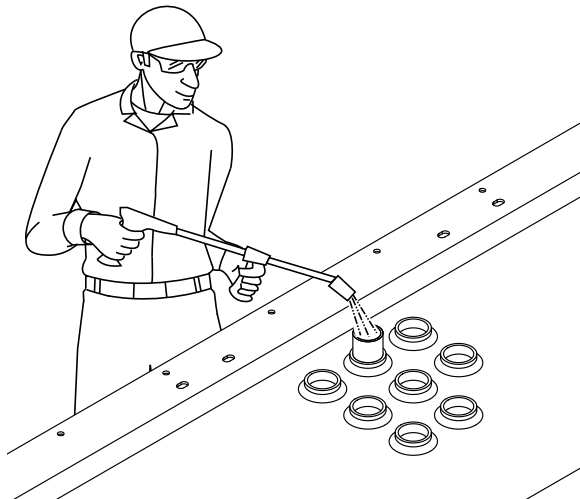

Figure 24. Fuel Tank Cleaning

FUEL TANK INSPECTION

In addition to cleaning the fuel tank, the following components should be inspected for wear:

- **Rubber Suspension** — look for signs of wear or deformity due to contact with oil. Replace the rubber suspension if necessary.
- **Fuel Hoses** — inspect nylon and rubber hoses for signs of wear, deterioration, and hardening.
- **Fuel Tank Lining** — inspect the fuel tank lining for signs of excessive amounts of oil and other foreign matter.

Replacing Fuel Filter

- Replace the fuel filter cartridge with a new one every 500 hours.
- Loosen the drain plug at the lower top of the fuel filter. Drain the fuel in the fuel body together with the mixed water. **DO NOT** spill the fuel during disassembly.
- Vent any air.

AIR REMOVAL

If air enters the fuel injection system of a diesel engine, starting becomes impossible. After running out of fuel, or after disassembling the fuel system, bleed the system. Refer to the Perkins engine manual for details.

CHECK OIL LEVEL

Check the crankcase oil level prior to each use, or when the fuel tank is filled. Insufficient oil may cause severe damage to the engine. The oil level must be between the two notches on the dipstick as shown in Figure 7.

Replacing Oil Filter

1. Remove the old oil filter.
2. Apply a film of oil to the gasket on the new oil filter.
3. Install the new oil filter.
4. After the oil filter has been replaced, the engine oil will drop slightly. Run the engine for a while and check for leaks before adding more oil if needed. Clean excessive oil from engine.

FLUSHING OUT RADIATOR AND REPLACING COOLANT

1. Remove radiator cap. Remove the coolant drain plug. Move the lever to the open position to start draining out coolant. See Figure 25.

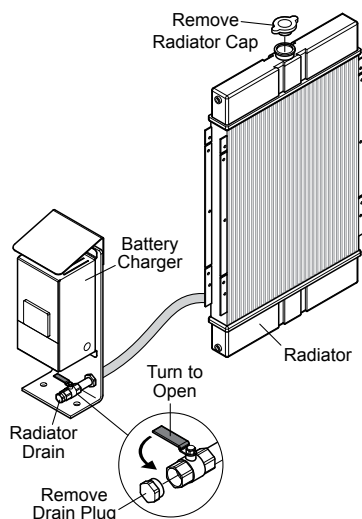

Figure 25. Draining Coolant

2. Flush the radiator by running clean tap water through radiator until signs of rust and dirt are removed. Do not clean radiator core with any objects, such as a screwdriver.
3. Check hoses for softening and kinks. Check clamps for signs of leakage.
4. Move lever to the closed position and reinstall coolant drain plug.
5. Replace with coolant as recommended by the engine manufacturer.
6. Close radiator cap tightly.

WARNING



Allow engine to **cool** before flushing out radiator. Flushing the radiator while hot could cause serious burns from water or steam.

RADIATOR CLEANING

The radiator (Figure 26) should be cleaned with a high-pressure washer when excessive amounts of dirt and debris have accumulated on the cooling fins or tube. When using a high pressure washer, stand at least 5 feet (1.5 meters) away from the radiator to prevent damage to the fins and tube.

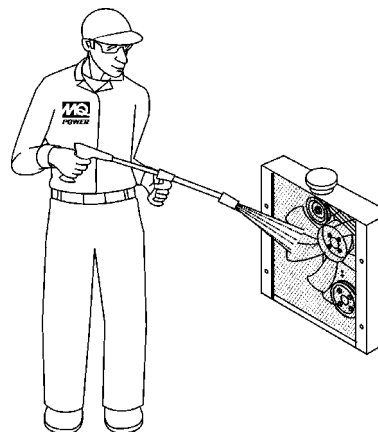

Figure 26. Radiator Cleaning

VOLTAGE REGULATOR ADJUSTMENTS

When the voltage regulator is defective or broken and is replaced, the following adjustment procedure needs to be performed on the newly installed voltage regulator.

Potentiometers

Figure 27 shows the screwdriver adjustable potentiometers on the front of the voltage regulator.

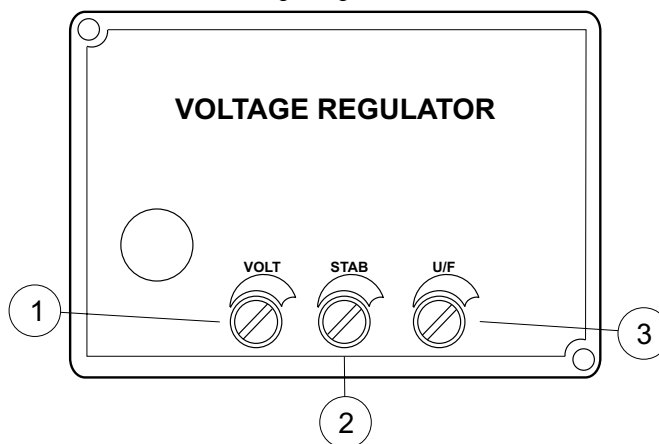

Figure 27. Voltage Regulator Potentiometers

1. **Coarse Voltage Adjust** — A screwdriver adjustable potentiometer on the front of the voltage regulator

used to adjust the generator output voltage. Clockwise adjustment increases the generator output voltage.

2. **Stability Adjust** — System stability is the ability of the generator to respond to load transients. Decreasing the stability makes the generator less sluggish and faster to respond to load transients.

If the stability of the regulator is decreased too much, the generator will tend to hunt under steady state conditions. Increasing stability increases the response time of the generator while decreasing stability decreases response time.

The screwdriver adjustable potentiometer is used to adjust the system stability. Clockwise adjustment increases stability.

3. **Roll-Off Frequency Selection** — The roll-off point is the frequency where the generator voltage starts to decrease. This reduces the kilowatt load to the engine, which allows the engine to recover in speed under any load transient condition.

The voltage regulator has the roll-off point preset to 58 Hz in the 60 Hz mode. To change the roll off point, perform the following:

- a. Adjust the engine to the desired rated speed (60 Hz).
- b. Set the voltage to the desired setting at rated speed.
- c. Adjust the engine speed to the desired roll-off point.
- d. Turn the potentiometer counterclockwise until the voltage returns to rated.
- e. Readjust the engine speed to rated speed.

Adjustment Procedure

1. Make sure that the voltage regulator is connected correctly to the generator. Refer to the generator wiring diagram.
2. Turn the Voltage Adjust potentiometer fully counterclockwise.
3. Turn Stability Adjust potentiometer fully clockwise.
4. Set the remote Voltage Adjust to the center position.
5. Connect the positive lead of a 100 VDC voltmeter to

F1 and the negative lead to F2 or use an appropriate AC voltmeter on the generator output leads.

6. Start and run the generator at no load and rated speed. The generator voltage should build up to a minimum level. If it does not build up, refer to the generator manual for field flashing information.
7. Slowly adjust the Voltage Adjust potentiometer until the generator voltage reaches the nominal value. Also adjust the remote Voltage adjust to set the generator voltage to the exact value desired.
8. Turn the Stability Adjust potentiometer counterclockwise until instability is shown on the voltmeter. With the system operating in an unstable condition, slowly adjust the Stability Adjust potentiometer clockwise until generator stability is reached.
9. Interrupt the regulator power for a short period of time (1 to 2 seconds).
10. If the generator remains stable, no further adjustment is necessary.
11. If generator does not remain stable, increase the stability slightly and interrupt the regular power again.
12. Repeat step 11 until system stability is reached and maintained.

GENERATOR STORAGE

For long term storage of the generator the following is recommended:

1. Drain the fuel tank completely. Treat with a fuel stabilizer if necessary.
2. Completely drain the oil from the crankcase and refill, if necessary, with fresh oil.
3. Clean the entire generator, inside and outside.
4. Disconnect the battery.
5. Make sure engine coolant is at proper level.
6. Cover the generator and store in a clean, and dry place.

TROUBLESHOOTING (GENERATOR)

Troubleshooting (Generator)		
Symptom	Possible Problem	Solution
No Voltage Output	AC Voltmeter defective?	Check output voltage using a voltmeter.
	Is wiring connection loose?	Check wiring and repair.
	Is voltage regulator defective?	Replace if necessary.
	Defective Rotating Rectifier?	Check and replace.
	Defective Exciter Field?	Check and replace.
Low Voltage Output	Is engine speed correct?	Turn engine throttle lever to "High".
	Is wiring connections loose?	Check wiring and repair.
	Defective AVR?	Replace if necessary.
High Voltage Output	Is wiring connections loose?	Check wiring and repair.
	Defective AVR?	Replace if necessary.
Circuit Breaker Tripped	Short Circuit in load?	Check load and repair.
	Over current?	Confirm load requirements and reduce.
	Defective circuit breaker?	Check and replace.
	Over current Relay actuated?	Confirm load requirement and replace.

TROUBLESHOOTING (ENGINE)

Troubleshooting (Engine)		
Symptom	Possible Problem	Solution
Engine will not start or start is delayed, although engine can be turned over.	No Fuel reaching injection pump?	Add fuel. Check entire fuel system.
	Defective fuel pump?	Replace fuel pump.
	Fuel filter clogged?	Replace fuel filter and clean tank.
	Faulty fuel supply line?	Replace or repair fuel line.
	Compression too low?	Check piston, cylinder and valves. Adjust or repair per engine repair manual.
	Fuel pump not working correctly?	Repair or replace fuel pump.
	Oil pressure too low?	Check engine oil pressure.
	Low starting temperature limit exceeded?	Comply with cold starting instructions and proper oil viscosity.
	Defective battery?	Charge or replace battery.
	Air or water mixed in fuel system?	Check carefully for loosened fuel line coupling, loose cap nut, etc.
At low temperatures engine will not start.	Engine oil too thick?	Refill engine crankcase with correct type of oil for winter environment.
	Defective battery?	Replace battery.
Engine fires but stops soon as starter is switched off.	Fuel filter blocked?	Replace fuel filter.
	Fuel supply blocked?	Check the entire fuel system.
	Defective fuel pump?	Replace fuel pump.
Engine stops by itself during normal operation.	Fuel tank empty?	Add fuel.
	Fuel filter blocked?	Replace fuel filter.
	Defective fuel pump?	Replace fuel pump.
	Mechanical oil pressure shutdown sensor stops the engine due to low oil?	Add oil. Replace low oil shutdown sensor if necessary.
Low engine power, output and speed.	Fuel tank empty?	Replace fuel filter.
	Fuel filter clogged?	Replace fuel filter.
	Fuel tank venting is inadequate?	Ensure that tank is adequately vented.
	Leaks at pipe unions?	Check threaded pipe unions tape and tighten unions as required.
	Speed control lever does not remain in selected position?	See engine manual for corrective action.
	Engine oil level too full?	Correct engine oil level.
	Injection pump wear?	Use No. 2-D diesel fuel only. Check the fuel injection pump element and delivery valve assembly and replace as necessary.

TROUBLESHOOTING (CONTROLLER)

⚠ CAUTION

Before opening the enclosure to perform troubleshooting or any service task, isolate the controller from any possible source of power. Failure to do so may result in serious personal injury or death due to electrical shock.

Troubleshooting (MEC20 Controller)		
Symptom	Possible Problem	Solution
Does not power up even with correct DC power applied	Wiring errors or short circuit?	Check wiring and repair. NOTE: The MEC 20 electronic fuse triggers when there is an overload condition and does not reset until the supply voltage is removed and overload condition is corrected.
LCD is not operational	Microprocessor defective?	Check that the "watchdog" LED on the rear of the PCB is flashing red meaning that the microprocessor is working. If not, repair or replace microprocessor.
	Insufficient DC supply voltage?	Check voltage at input terminals B+ and B- (10-30 VDC).
	Bad LCD resolution?	Adjust LCD contrast potentiometer (R115) on the rear of PCB for good pixel resolution for the operating temperature of the unit.
Controller cannot be "reset"	Controller not in OFF mode?	Check that the controller is set to the OFF mode before resetting.
	Engine is running?	Check that the engine has come to a complete stop before resetting.
No "RUN" output signal	Shutdown circuits reset?	Check that all shutdown circuits are reset (red shutdown LED must be off).
	No engine speed signal?	Engine speed signal must be detected (speed signal green LED on) during cranking if the "run-output fail safe" feature is enabled. Verify correct magnetic pick-up signal at cranking (2.0 VAC min.)
	RUN output LED off?	Check that the RUN output LED (on the rear of the PCB) is on. If yes, verify relay contact operation on terminals #18 and #19.
Overspeed shutdown occurs at normal speed	Controller not correctly programmed?	Verify that the controller has been programmed with the correct values for the number of flywheel teeth, nominal RPM, and overspeed setpoint percentage.
Voltage or current metering is reading incorrectly	Controller not correctly programmed?	Verify that the controller has been programmed with the correct values for voltage sensing PT ratio and/or current sensing CT ratio.
	Battery not properly grounded?	Verify that the battery supply DC negative conductor is properly grounded to the engine block (i.e. to a common ground point.)
	Analog input not properly calibrated?	Verify that the controller's analog input has been properly calibrated.
	Incorrect wiring?	Verify that the voltage sensing wiring connection to the controller matches power distribution type (Note: standard direct voltage connection requires that the generator's neutral is solidly grounded).

TROUBLESHOOTING (CONTROLLER)

Troubleshooting (MEC20 Controller) - continued		
Symptom	Possible Problem	Solution
Engine temperature or oil pressure display is reading incorrectly	Improper calibration?	Verify that the controller's analog input has been properly calibrated as per manual instructions.
	Incorrect engine sensor wiring?	Verify that the engine sensor wiring is correct (Note: Use factory-supplied engine sensors only.)
	Battery not properly grounded?	Verify that the battery supply DC negative conductor is properly grounded to the engine block (i.e. to a common ground point.)
Engine temperature or oil displays "9999"	Incorrect wiring?	Check that the wiring from the controller terminal #37 and #38 to the engine mounted sender is correct (i.e. wiring is not open or shorted).
	Incorrect resistance?	Verify that the engine mounter senders have correct resistance reading for corresponding input temperature or pressure (refer to Controller manual).
	Improper calibration?	Verify calibration.
Engine alarms on high engine temperature or low oil pressure when engine is operating within normal limits	Incorrect wiring?	Check that the wiring from the controller terminal #37 and #38 to the engine mounted sender is correct (i.e. wiring is not open or shorted).
	Incorrect resistance?	Verify that the engine mounter senders have correct resistance reading for corresponding input temperature or pressure (refer to Controller manual).
Keys on faceplate do not operate.	Incorrect connection?	Verify that the interconnecting ribbon cable between the faceplate and the main printed circuit board is connected correctly.

TROUBLESHOOTING (VOLTAGE REGULATOR)

Troubleshooting (Voltage Regulator)		
Symptom	Possible Problem	Solution
Residual Voltage - No output	Residual Voltage at regulator power input wires 3 and 4 below 10 VAC?	Check wiring diagram for proper connections.
		Flash generator speed. Refer to field flashing section in generator manual.
	Accelerated time to rated speed too long?	Reduce acceleration time.
		Interrupt power input to regulator after achieving rated speed.
	Field leads F1, F2 not connected?	Connect field leads F1, F2.
	Power input leads not connected?	Connect power input leads 3, 4.
	Blown or missing fuse?	Replace fuse.
	Defective regulator?	Replace regulator.
Defective generator?	Consult generator manual.	
Output Voltage Low	Incorrect connections?	Check wiring diagram for proper connections.
	Voltage Adjust turned down?	Rotate Voltage Adjust clockwise until the desired voltage is reached.
	Remote Voltage Adjust is turned down?	Rotate remote Voltage Adjust clockwise until the desired voltage is reached.
	Defective regulator?-	Replace regulator.
Output Voltage High	Voltage Adjust turned too high?	Rotate Voltage Adjust counterclockwise until the desired voltage is reached.
	Remote Voltage Adjust is turned too high?	Rotate remote Voltage Adjust counterclockwise until the desired voltage is reached.
Output Voltage High - No Adjustment	Defective regulator?	Replace regulator.
Remote Voltage Adjust Operates Backwards	Voltage adjust wire connected backwards?	Reverse the wiring of the remote Voltage Adjust.
Generator Output Voltage Hunting	Stability Adjust not set properly?	Rotate the Stability Adjust clockwise until hunting stops.
Poor regulation	Defective regulator?	Replace regulator.

MAINTENANCE PARTS LOCATOR

Refer to Figure 28 for the location of the components in the generator wiring diagram.

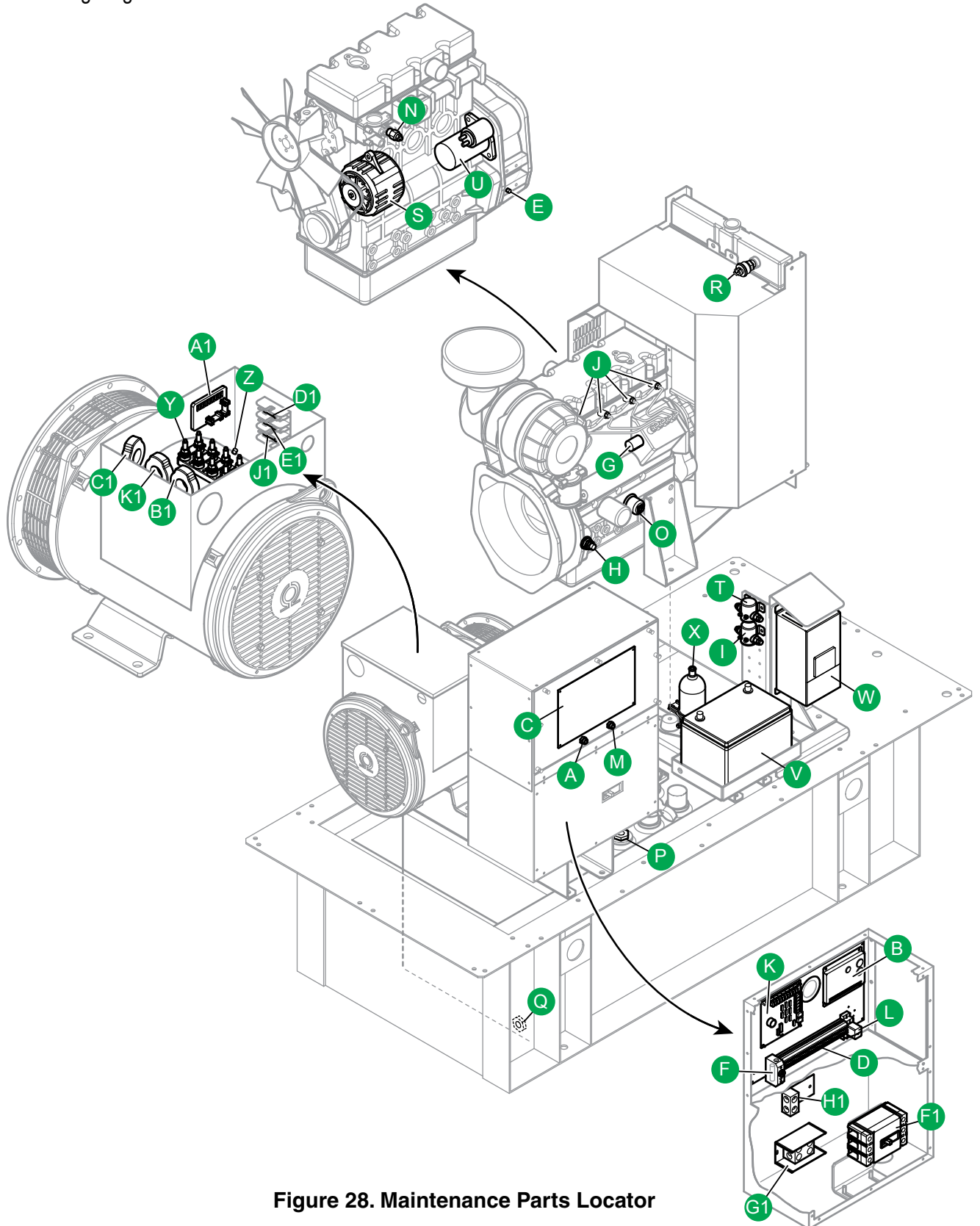
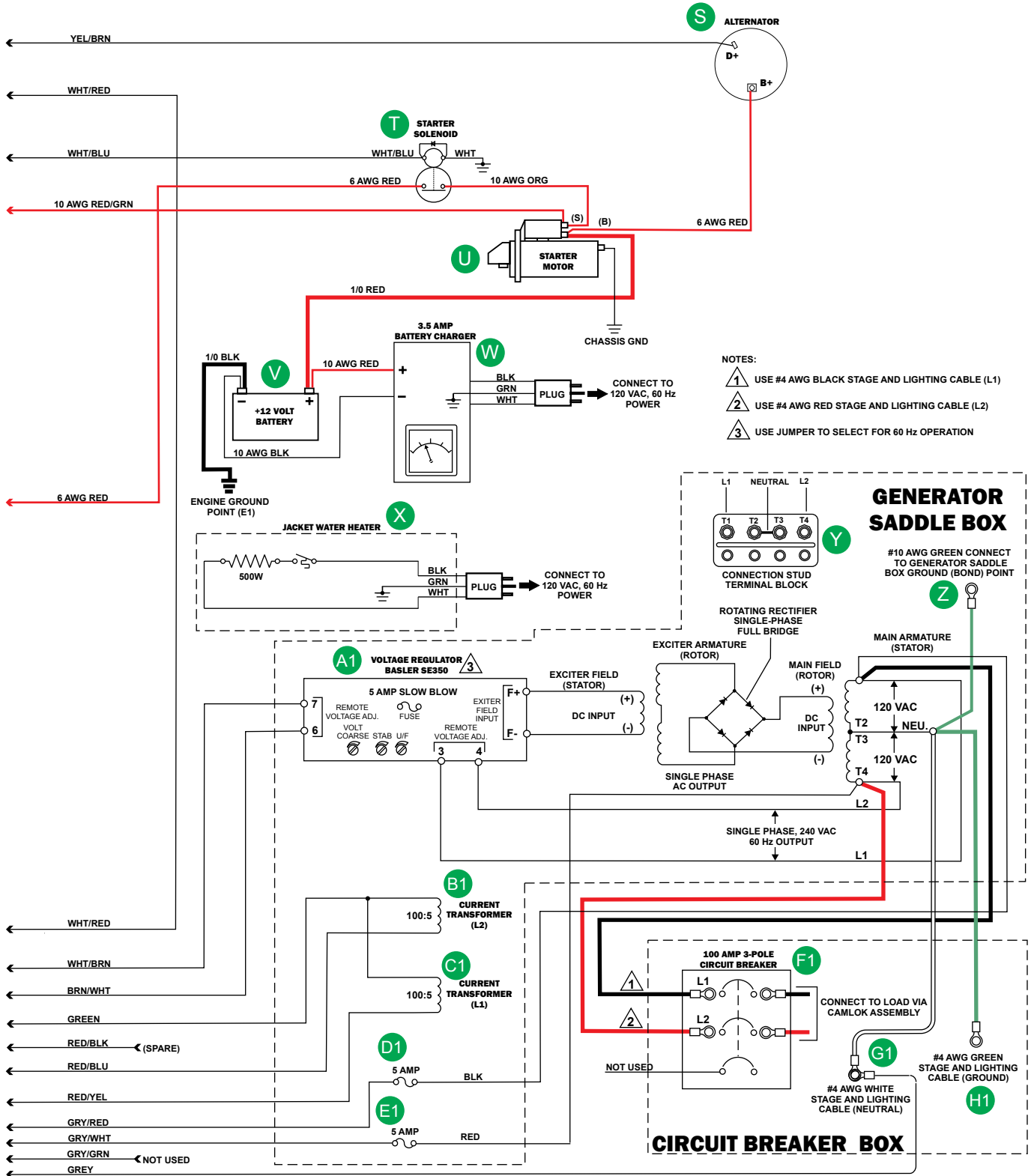
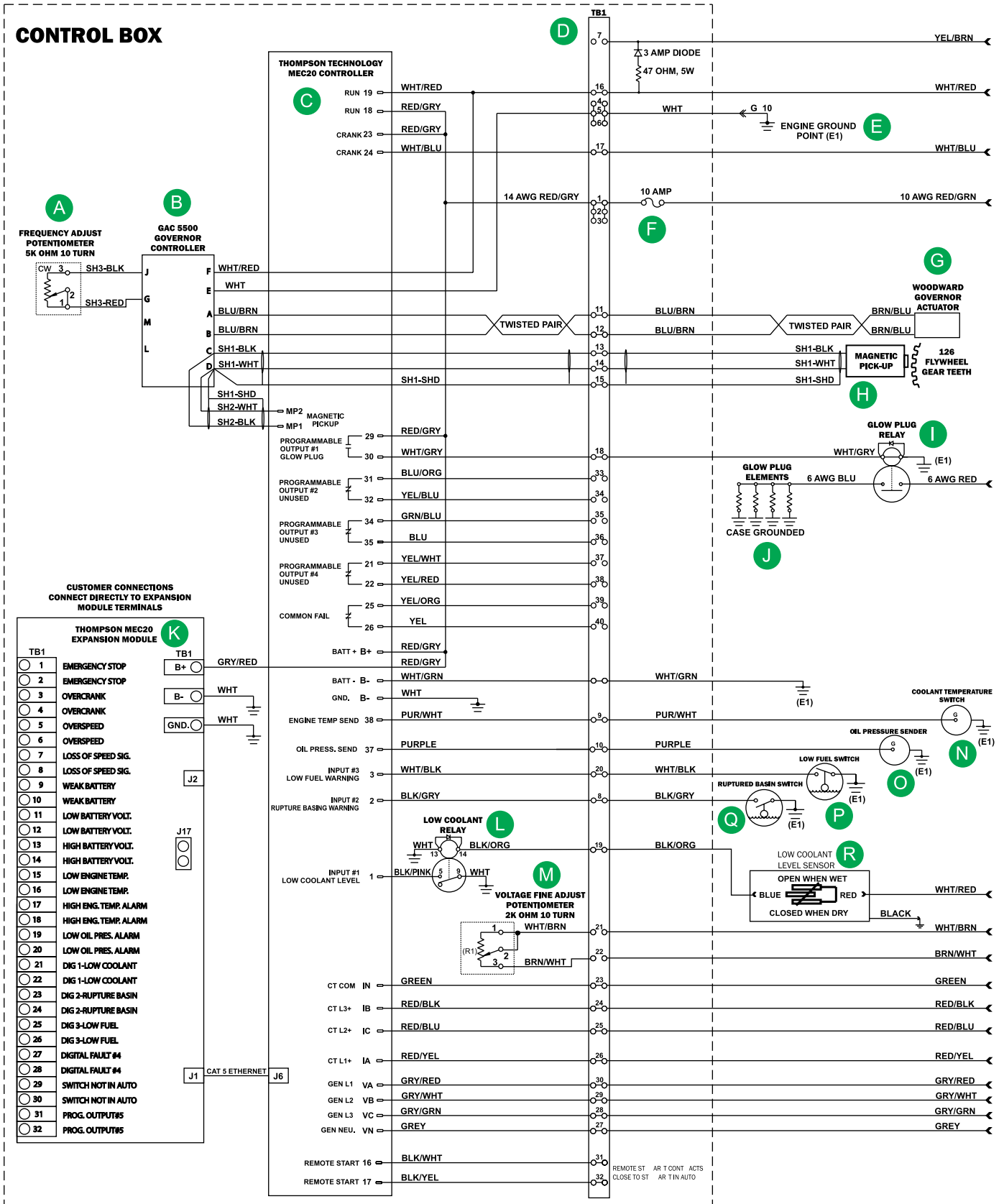

Figure 28. Maintenance Parts Locator

GENERATOR WIRING DIAGRAM (SINGLE PHASE)



GENERATOR WIRING DIAGRAM (THREE PHASE)



GENERATOR WIRING DIAGRAM (THREE PHASE)

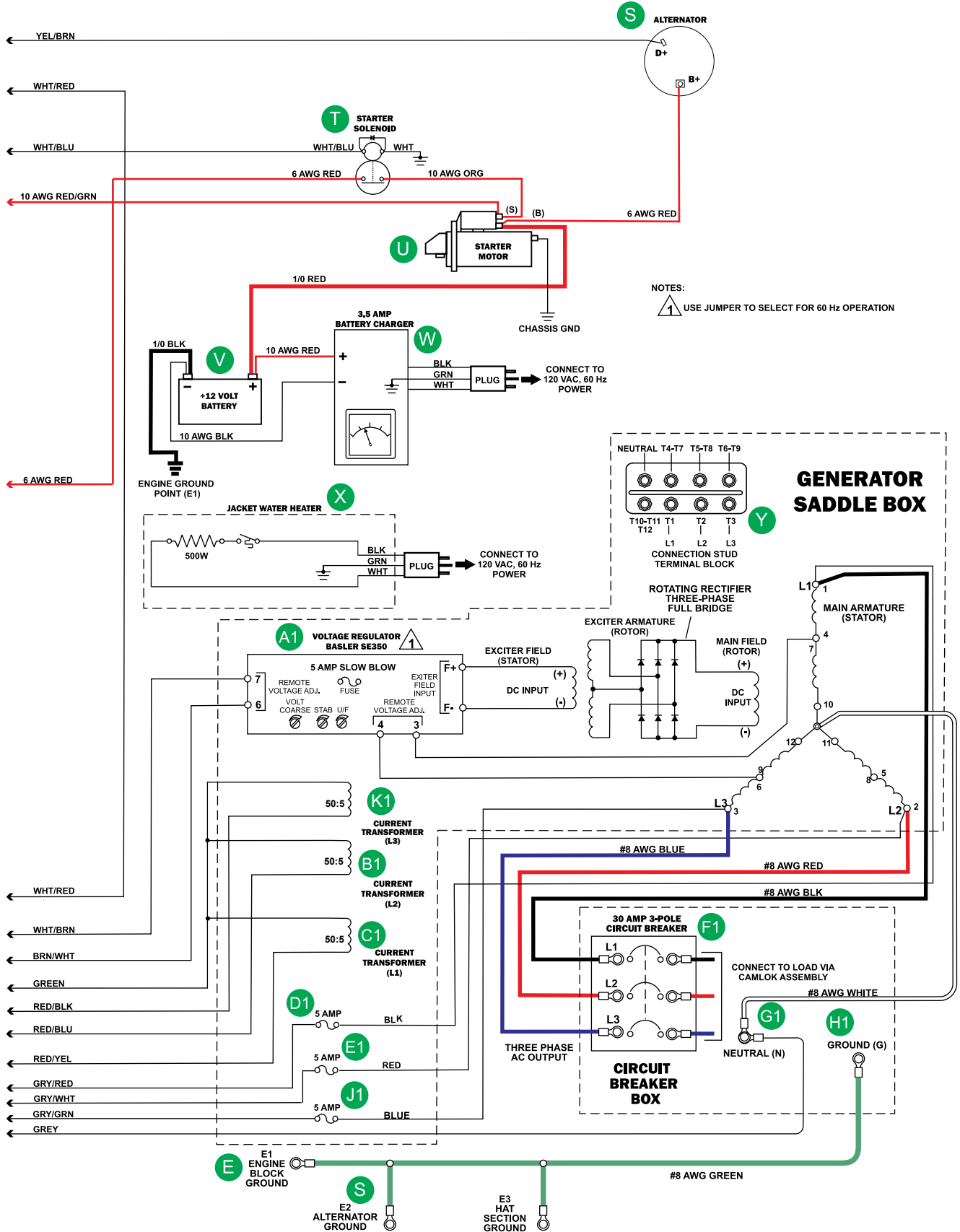

EXPLANATION OF CODE IN REMARKS COLUMN

The following section explains the different symbols and remarks used in the Parts section of this manual. Use the help numbers found on the back page of the manual if there are any questions.

NOTICE

The contents and part numbers listed in the parts section are subject to change **without notice**. Multiquip does not guarantee the availability of the parts listed.

SAMPLE PARTS LIST

NO.	PART NO.	PART NAME	QTY.	REMARKS
1	12345	BOLT	1	INCLUDES ITEMS W/%
2%		WASHER, 1/4 IN.		NOT SOLD SEPARATELY
2%	12347	WASHER, 3/8 IN. ...	1	MQ-45T ONLY
3	12348	HOSE	A/R	MAKE LOCALLY
4	12349	BEARING	1	S/N 2345B AND ABOVE

NO. Column

Unique Symbols — All items with same unique symbol

(@, #, +, %, or >) in the number column belong to the same assembly or kit, which is indicated by a note in the “Remarks” column.

Duplicate Item Numbers — Duplicate numbers indicate multiple part numbers, which are in effect for the same general item, such as different size saw blade guards in use or a part that has been updated on newer versions of the same machine.

NOTICE

When ordering a part that has more than one item number listed, check the remarks column for help in determining the proper part to order.

PART NO. Column

Numbers Used — Part numbers can be indicated by a number, a blank entry, or TBD.

TBD (To Be Determined) is generally used to show a part that has not been assigned a formal part number at the time of publication.

A blank entry generally indicates that the item is not sold separately or is not sold by Multiquip. Other entries will be clarified in the “Remarks” Column.

QTY. Column

Numbers Used — Item quantity can be indicated by a number, a blank entry, or A/R.

A/R (As Required) is generally used for hoses or other parts that are sold in bulk and cut to length.

A blank entry generally indicates that the item is not sold separately. Other entries will be clarified in the “Remarks” Column.

REMARKS Column

Some of the most common notes found in the “Remarks” Column are listed below. Other additional notes needed to describe the item can also be shown.

Assembly/Kit — All items on the parts list with the same unique symbol will be included when this item is purchased.

Indicated by:

“INCLUDES ITEMS W/(unique symbol)”

Serial Number Break — Used to list an effective serial number range where a particular part is used.

Indicated by:

“S/N XXXXX AND BELOW”

“S/N XXXX AND ABOVE”

“S/N XXXX TO S/N XXX”

Specific Model Number Use — Indicates that the part is used only with the specific model number or model number variant listed. It can also be used to show a part is NOT used on a specific model or model number variant.

Indicated by:

“XXXXX ONLY”

“NOT USED ON XXXX”

“Make/Obtain Locally” — Indicates that the part can be purchased at any hardware shop or made out of available items. Examples include battery cables, shims, and certain washers and nuts.

“Not Sold Separately” — Indicates that an item cannot be purchased as a separate item and is either part of an assembly/kit that can be purchased, or is not available for sale through Multiquip.

SUGGESTED SPARE PARTS

MQP20P WITH PERKINS 404D-22 DIESEL ENGINE

1 to 3 units

Qty.	P/N	Description
1	140517050	OIL FILTER
6	26561117	KIT, FUEL FILTER
1	130506300	PRIMER
1	GPC1000	SENSOR, LOW FUEL
1	U85046501	ALTERNATOR
2	EE2916	RELAY, STARTER SOLENOID, COLE HERSEE, 12V
1	EE46269	SENSOR, COOLANT LEVEL
1	MEC000788	SENSOR, WATER TEMPERATURE
1	U45537130	HOSE, RADIATOR, UPPER
1	U45537140	HOSE, RADIATOR LOWER
1	145996051	GASKET, THERMOSTAT
1	145206230	THERMOSTAT
1	U45010062	WATER PUMP
3	080109107	BELT
1	24850072	RADIATOR CAP
3	135326206	ELEMENT, AIR FILTER
1	MEC003654	SENSOR, OIL PRESSURE
5	EE5812	FUSE, 10 AMP
5	EE5811	FUSE, 5 AMP
3	A-527066-1	FUSE, 5 AMP, SLOW BLOW
1	EE10997	CIRCUIT BREAKER, CUTLER HAMMER, 3-POLE, 100A

NOTICE

Part numbers on this Suggested Spare Parts list may supersede/replace the part numbers shown in the following parts lists.

HOUSING ASSY.

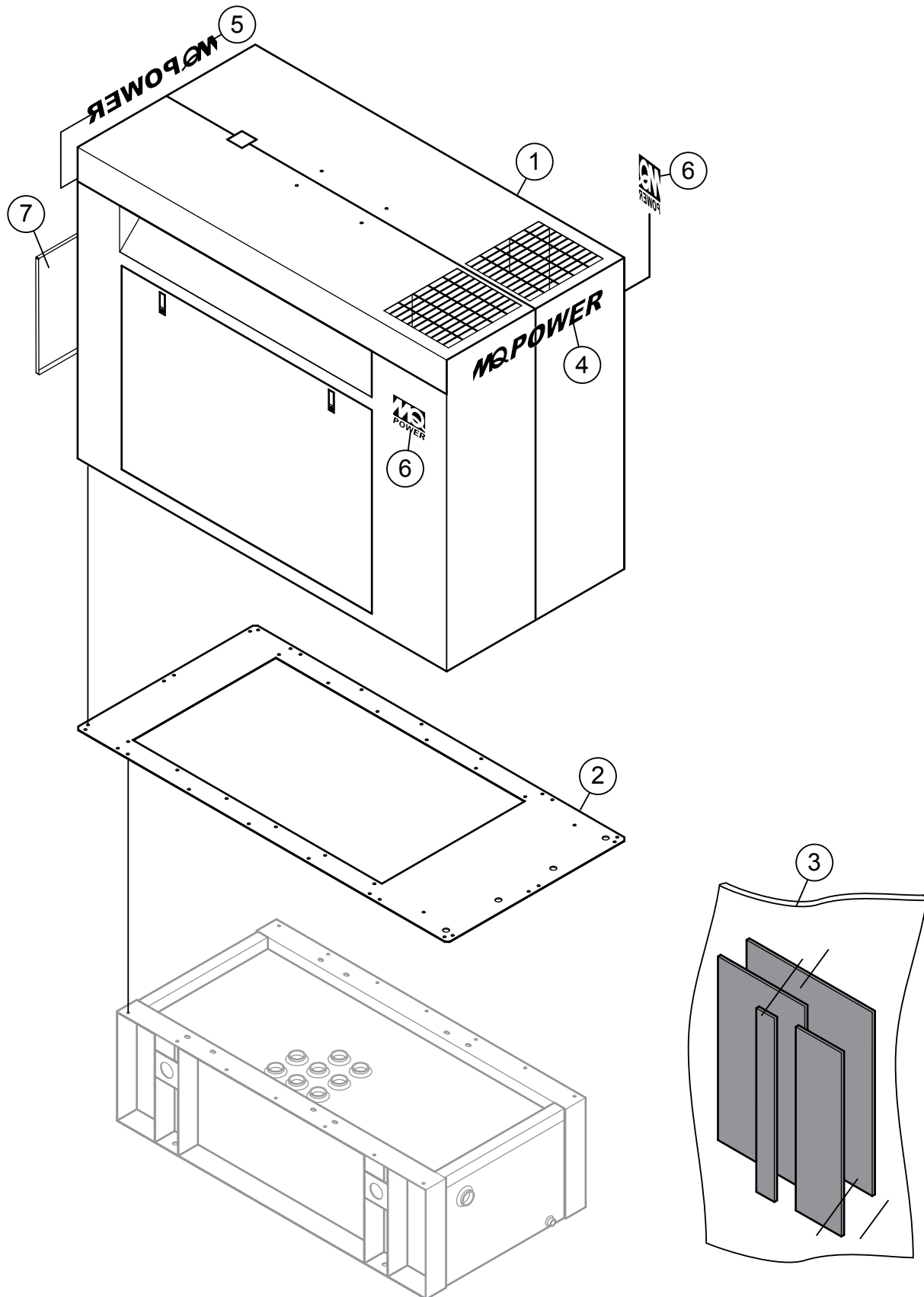

HOUSING ASSY.

<u>NO.</u>	<u>PART NO.</u>	<u>PART NAME</u>	<u>QTY.</u>	<u>REMARKS</u>
1	EE40861	HOUSING ASSY., PAINTED WHITE, W/ INSULATION	1	
2	EE40727	FLANGE, ADAPTOR, ENCLOSURE TO FUEL TANK	1	
3	EE54214	KIT, INSULATION	1	
4	EE33427	MQ POWER DECAL BLACK	1	
5	EE33424	MQ POWER DECAL RED	1	
6	EE33425	MQ POWER DECAL RED	2	
7	EE42018	PANEL COVER	1	

ENGINE AND GENERATOR MOUNTING ASSY.

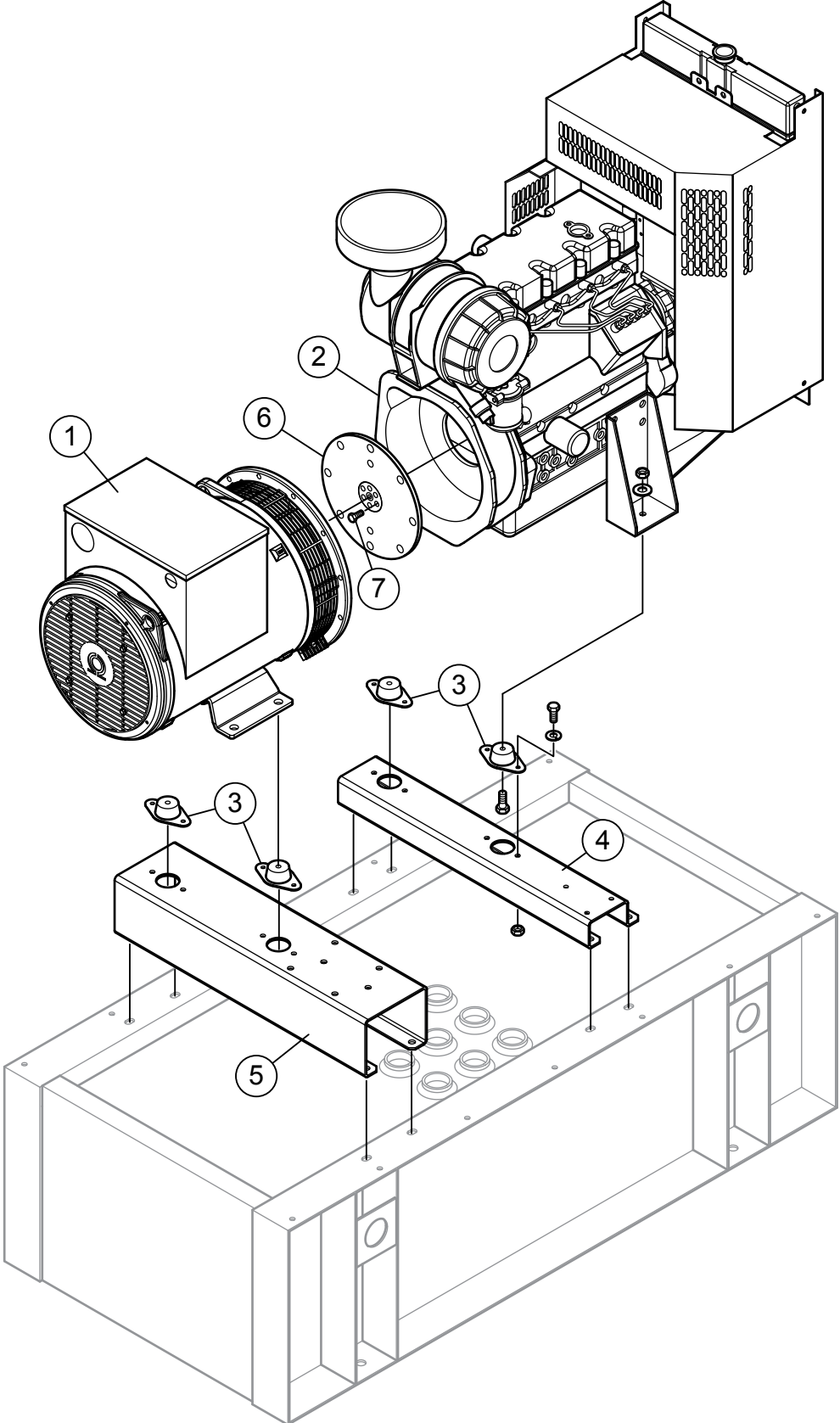

ENGINE AND GENERATOR MOUNTING ASSY.

<u>NO.</u>	<u>PART NO.</u>	<u>PART NAME</u>	<u>QTY.</u>	<u>REMARKS</u>
1	EE46389	GENERATOR, 30KW	1	
2	EE54153	ENGINE, PERKINS 21.3KW 404D-22	1	
3	EE40907	MOUNT, COMPRESSION	4	
4	EE54212	CROSS MEMBER, ENGINE	1	
5	EE54211	CROSS MEMBER, GENERATOR	1	
6	EE54208	DRIVE DISC	2	
7	EE54209	BOLT, DRIVE DISC	6	

FUEL ASSY.

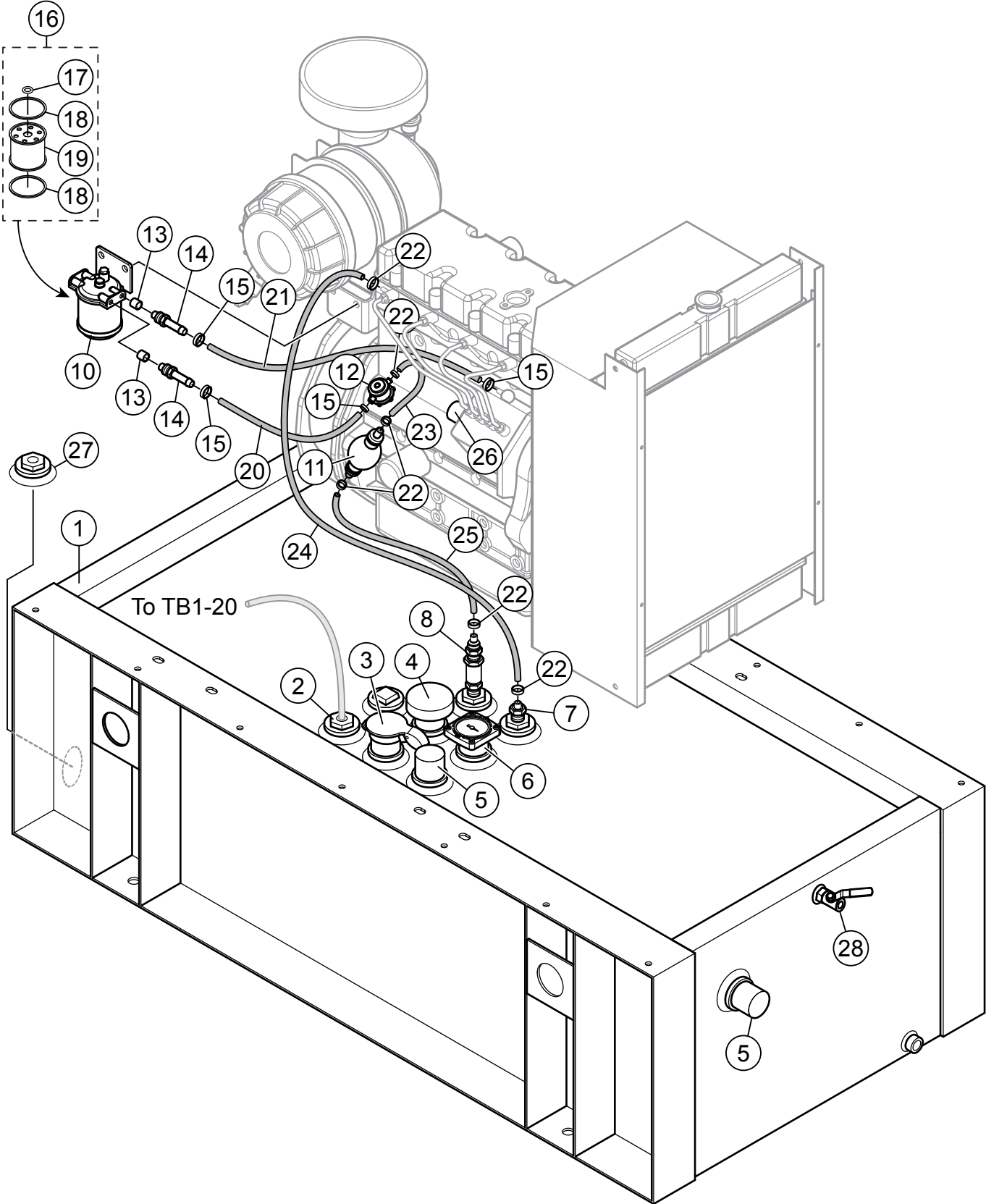

FUEL ASSY.

<u>NO.</u>	<u>PART NO.</u>	<u>PART NAME</u>	<u>QTY.</u>	<u>REMARKS</u>
1	EE40871	TANK, FUEL, SUB BASE, 50 GAL	1	
2	GPC1000	SENSOR, LOW FUEL	1	
3	GPC 3005	CAP, FUEL TANK, LOCKING (2IN NPT)	1	
4	GPC 3152	CAP, STANDARD VENT	1	
5	GPC 3162	CAP, EMERGENCY PRESSURE RELIEF	2	
6	GPC 1003	GAUGE, FUEL	1	
7	GPC3600	FITTING, FUEL RETURN	1	
8	GPC3600	FITTING, FUEL SUPPLY	1	
10	2656613	FUEL FILTER ASSY.	1	
11	130506300	PRIMER	1	
12	130506350	LIFT PUMP	1	
13	33811114	OLIVE	2	
14	131246290	PIPE, LOW PRESSURE FUEL	2	
15	067100015	CLIP	4	
16	26561117	FUEL FILTER KIT	1.....	INCLUDES ITEMS W/@
17@	26560014	SEAL, O-RING	1	
18@	0490786	SEAL	2	
19@		ELEMENT, FUEL FILTER	1.....	MUST PURCHASE KIT
20	068209126	HOSE	1	
21	068209227	PIPE, FUEL	1	
22		CLAMP, HOSE 5/16IN OETTIKER	6.....	OBTAIN LOCALLY
23		HOSE, FUEL, 5/16IN X 8IN	1.....	OBTAIN LOCALLY
24		HOSE, FUEL 3/16IN X 3FT	1.....	OBTAIN LOCALLY
25		HOSE, FUEL, 5/16IN X 14IN	1.....	OBTAIN LOCALLY
26	EE55628	GOVENOR ACTUATOR	1	
27	GPC4306	ALARM, FLOAT, FUEL, IN BASIN	1	
28	944-116	BALL VALVE W/ RED HANDLE	1	

ELECTRICAL ASSY.

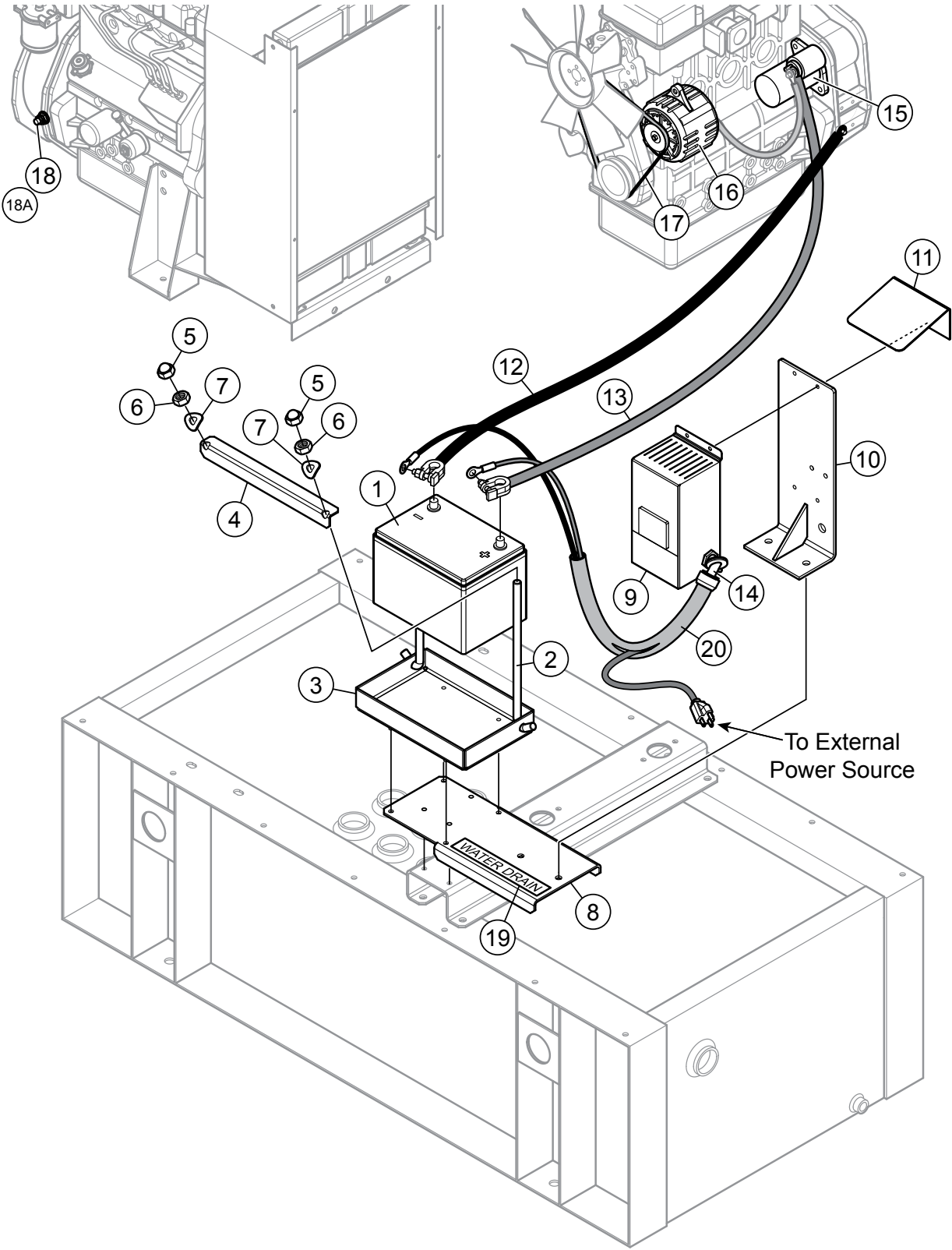

ELECTRICAL ASSY.

<u>NO.</u>	<u>PART NO.</u>	<u>PART NAME</u>	<u>QTY.</u>	<u>REMARKS</u>
1	EE46626	BATTERY, MAINT. FREE, GROUP 24, 800	1	
2	EE34486	J-BOLT, BATTERY, 10.38 IN.	2	
3	EE38190	TRAY, BATTERY	1	
4	EE25596	BATTERY HOLD DOWN	1	
5		NUT, ACORN CAP, 5/16-18, SS	2.....	OBTAIN LOCALLY
6		NUT, NYLOCK 55, 5/16-18, SS	2.....	OBTAIN LOCALLY
7	EE40908	WASHER, SNUBBING 2.0" O.D, .45" I.D.	2	
8	EE40904	BRACKET, MTG., BATTERY TRAY AND CHARGER	1	
9	EE31218	CHARGER, BATTERY, AUTO, FLOAT EQ	1	
10	EE34068	BRACKET, SENS LC CHARGER MNTING	1	
11	EE36506	COVER, RAIN, BATTERY CHARGER	1	
12		CABLE, BATTERY, NEGATIVE BLACK,	1.....	MAKE LOCALLY 5/16-10 GA EYE TERMINAL 5'8" LONG
13		CABLE, BATTERY, NEGATIVE RED,.....	1.....	MAKE LOCALLY 5/16-10 GA EYE TERMINAL 5'8" LONG
14	EE6009	FITTING, CONDUIT, 90°, NON-METALLIC	1	
15	185086600	STARTER MOTOR	1	
16	U85046501	ALTERNATOR	1	
17	080109107	BELT	1	
18	EE2543	MAGNETIC PCKUP W/ WIRES (RED/BLCK)	1	
18A	EE54416	ADAPTER, MAGNETIC PICK-UP	1	
19	EE7315	PLACARD, WATER DRAIN	1	
20	EE22218	3/8" SPLIT LOOM	3FT	

JACKET WATER HEATER ASSY.

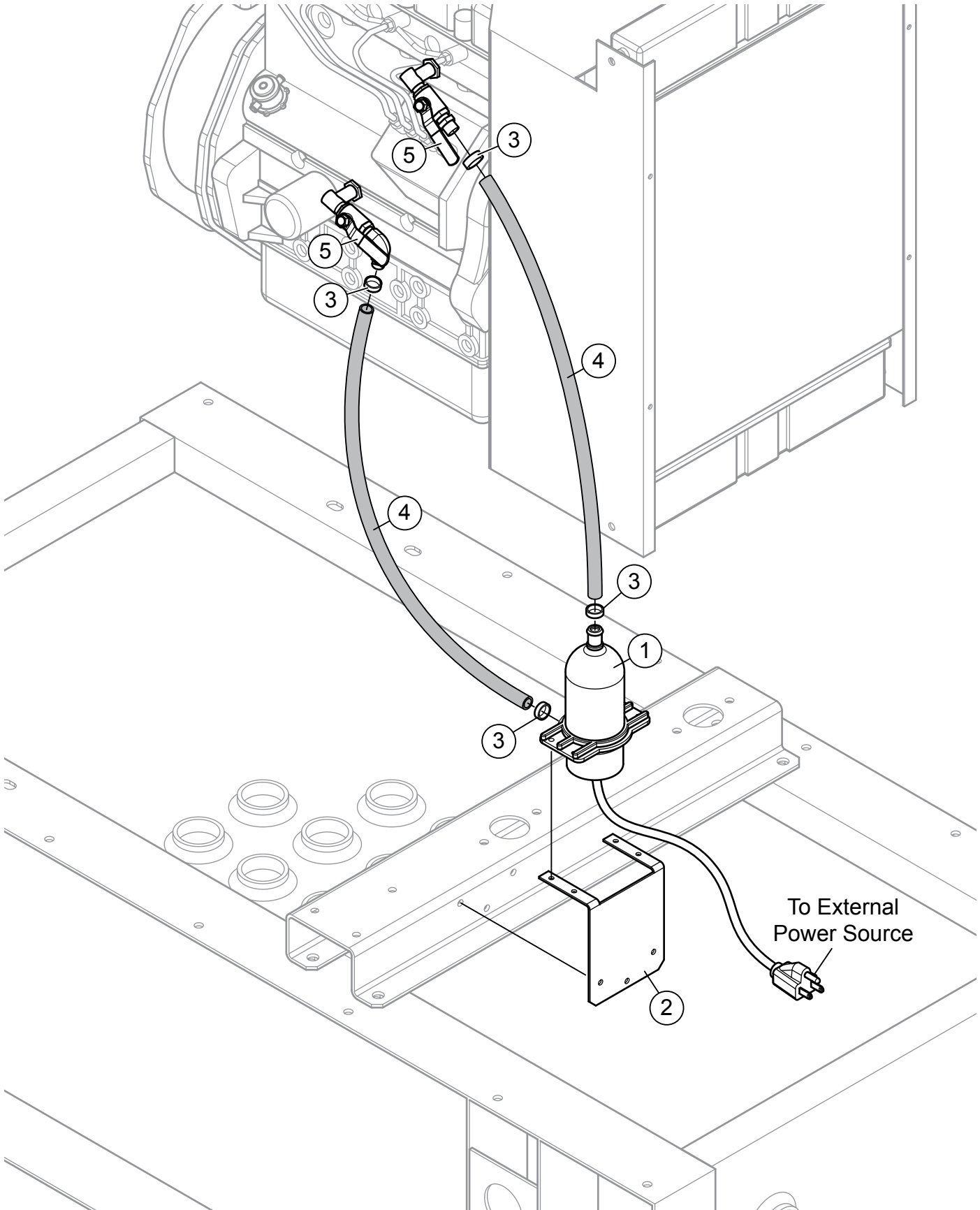

JACKET WATER HEATER ASSY.

<u>NO.</u>	<u>PART NO.</u>	<u>PART NAME</u>	<u>QTY.</u>	<u>REMARKS</u>
1	EE40205	HEATER, ENGINE BLOCK, TANK STYLE	1	
2	EE40939	BRACKET, MOUNTING, HEATER	1	
3		CLAMP, HOSE #10 (SILICONE STYLE)	4.....	OBTAIN LOCALLY
4		HOSE, HEATER, HI-MILLER, 5/8IN X 2FT	2.....	OBTAIN LOCALLY
5	EE18071	VALVE, LOCKING BALL, 3/8IN INLET	2	

SOLENOID ASSY.

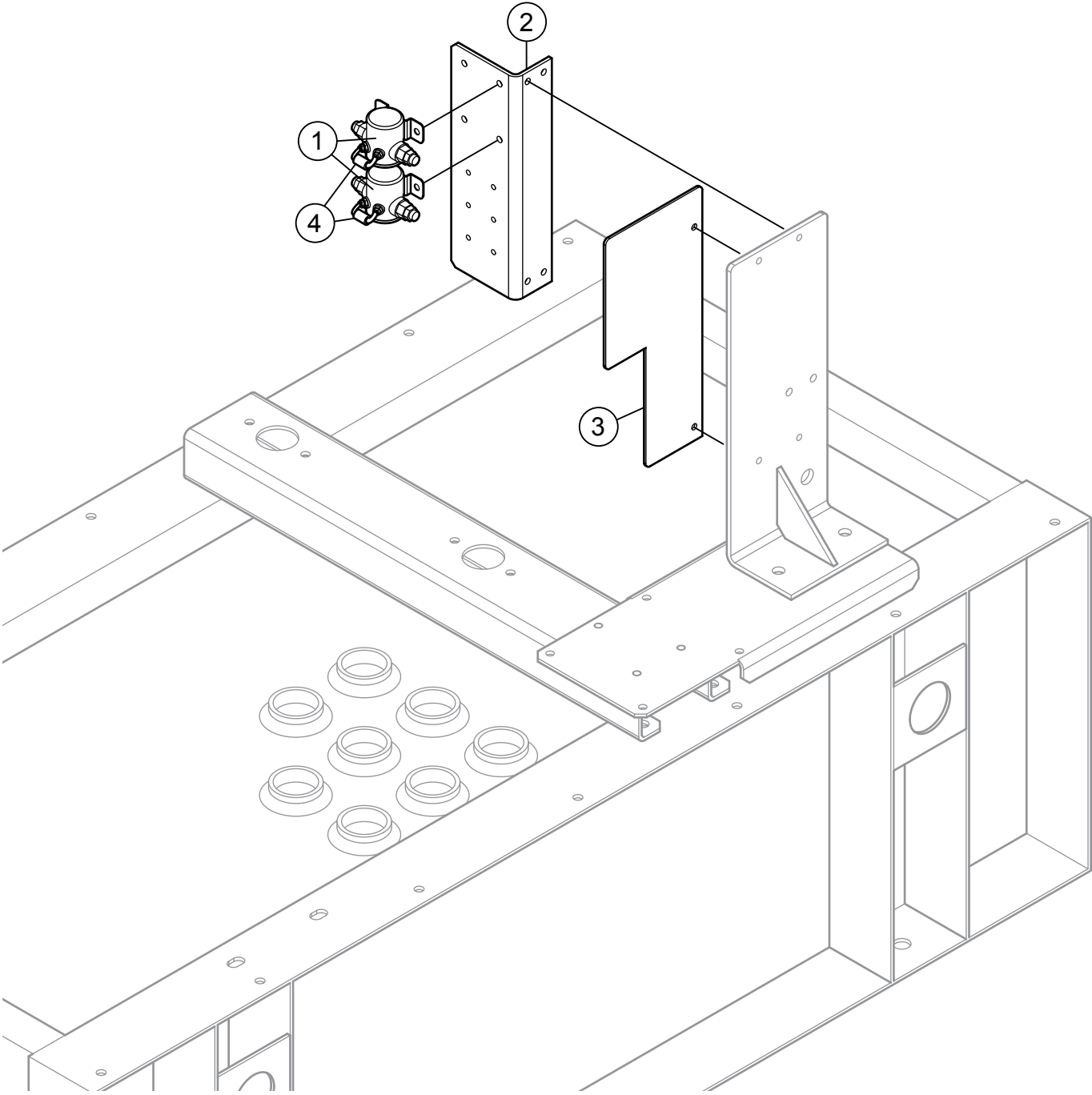

SOLENOID ASSY.

<u>NO.</u>	<u>PART NO.</u>	<u>PART NAME</u>	<u>QTY.</u>	<u>REMARKS</u>
1	EE2916	RELAY, STARTER SOLENOID, 12V	2	
2	EE41370	BRACKET, STARTER SOLENOID	1	
3	EE41595	SHIELD, LEXAN COVER, SOLENOID	1	
4	EE5736	DIODE, /AMP	2	

RADIATOR ASSY.

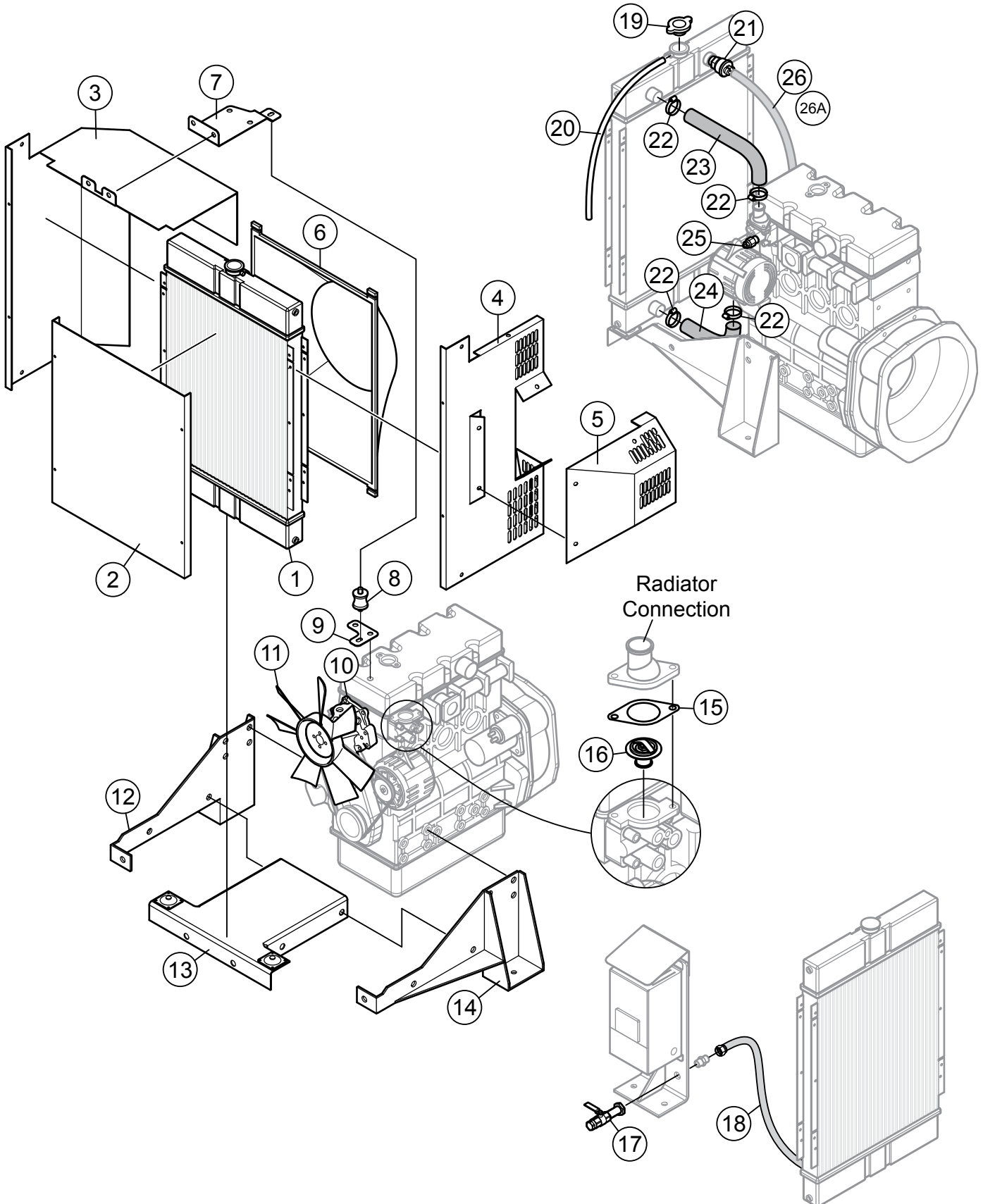

RADIATOR ASSY.

<u>NO.</u>	<u>PART NO.</u>	<u>PART NAME</u>	<u>QTY.</u>	<u>REMARKS</u>
1	TPN440	RADIATOR.....	1.....	INCLUDES ITEMS W/@
2	U45546860	GUARD	1	
3	U75316330	FAN GUARD	1	
4	U75316371	FAN GUARD	1	
5	U75316312	GUARD	1	
6@	24850083	SHROUD	1	
7	U45977221	BRACKET	1	
8	U98116931	MOUNTING	1	
9	U45977201	BRACKET	1	
10	U45010062	WATER PUMP	1	
11	145306880	FAN	1	
12	U10267271	BRACKET	1	
13	U45976820	BRACKET	1	
14	U10267291	BRACKET	1	
15	145996051	GASKET, THERMOSTAT	1	
16	145206230	THERMOSTAT	1	
17	944-116	VALVE, DRAIN, MINI BALL 1/4IN NPT	1	
18		HOSE, DRAIN, INSTA-GRIP 3/8-13.5IN.....	1.....	MAKE LOCALLY
19@	24850072	RADIATOR CAP	1	
20@		HOSE, 1/4IN I.D. X 32IN.....	1.....	MAKE LOCALLY
21	EE46221	SENSOR, COOLANT LEVEL	1	
22	0180067	CLAMP	4	
23	U45537130	HOSE, RADIATOR UPPER	1	
24	U45537140	HOSE, RADIATOR LOWER	1	
25	MEC000788	SENSOR, WATER TEMP.	1	
26	EE10696	KIT, WIRING HARNESS COOLANT SENSR	1	
26A	EE22218	SPLIT LOOM, 3/8IN	3FT	

AIR FILTER ASSY.

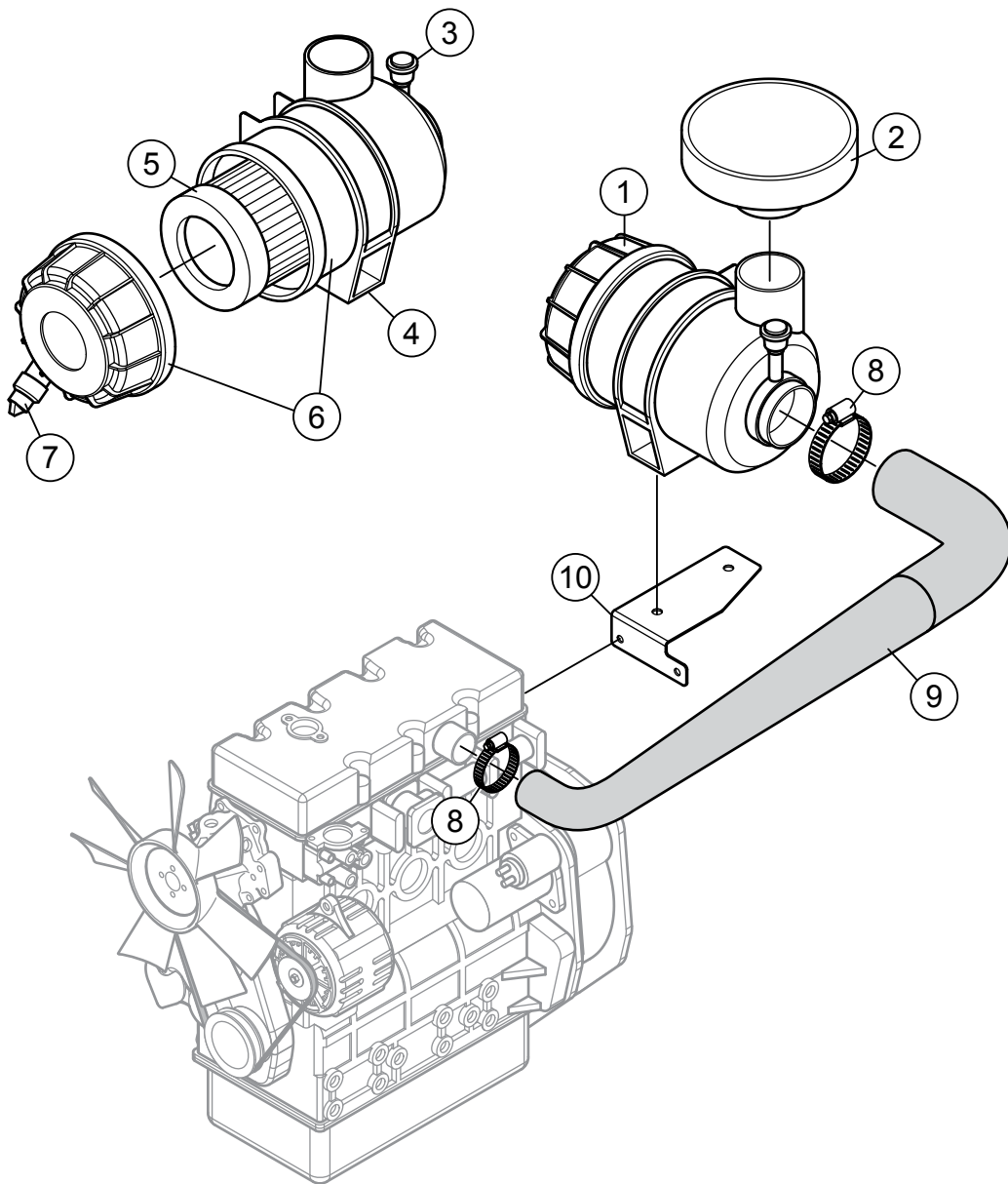

AIR FILTER ASSY.

<u>NO.</u>	<u>PART NO.</u>	<u>PART NAME</u>	<u>QTY.</u>	<u>REMARKS</u>
1	135016350	AIR FILTER ASSY.....	1.....	INCLUDES ITEMS W/@
2	W14501020	COVER	1	
3@	26510402	INDICATOR	1	
4@	26510418	BRACKET	1	
5@	135326206	ELEMENT, AIR FILTER	1	
6@		BODY	1.....	NOT SERVICED SEPARATELY
7@	26510194	VALVE	1	
8	21825194	CLAMP	2	
9	U35597790	HOSE	1	
10	U30976791	BRACKET	1	

ENGINE EXHAUST ASSY.

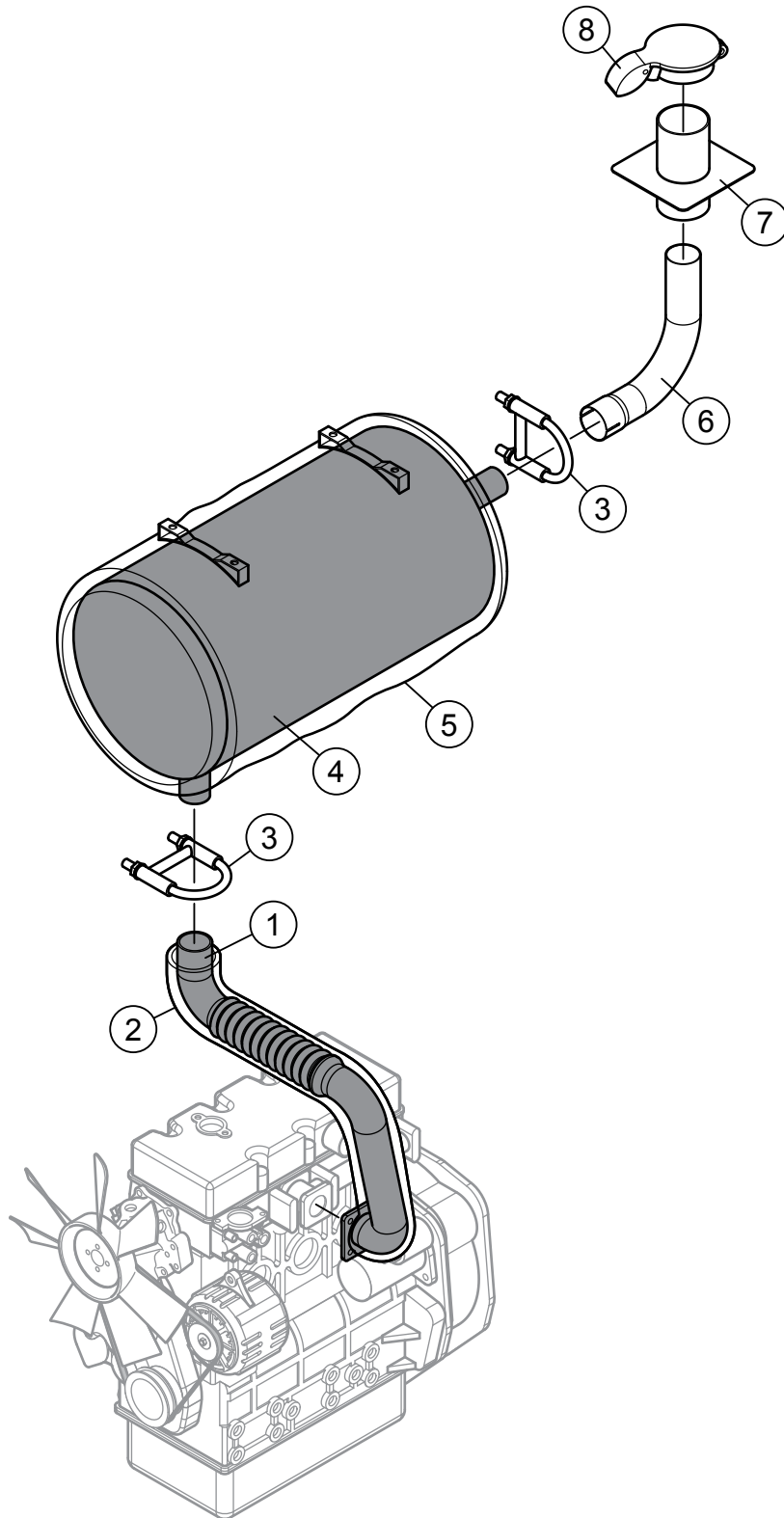

ENGINE EXHAUST ASSY.

<u>NO.</u>	<u>PART NO.</u>	<u>PART NAME</u>	<u>QTY.</u>	<u>REMARKS</u>
1	EE54297	EXHAUST FLEX	1	
2	EE9925	INSULATION, GLASS GASKET TAPE	1	
3	EE41113	CIA, U-STYLE, ZIN PLATED	2	
4	EE40950	SILENCER, 2 IN IN/OUT W/ BLANKET ASSY.	1	
5	IBJB2SI6CSGA	COVER, BLANKET ASSY	1	
6	EE41076	ELBOW, EXHAUST 2 IN	1	
7	EE6971	ASSY, W/ FLANGE & NIPPLE, EXHAUST	1	
8	EE16610	RAIN CAP, ALUM, 2-1/2IN	1	

ENGINE OIL ASSY.

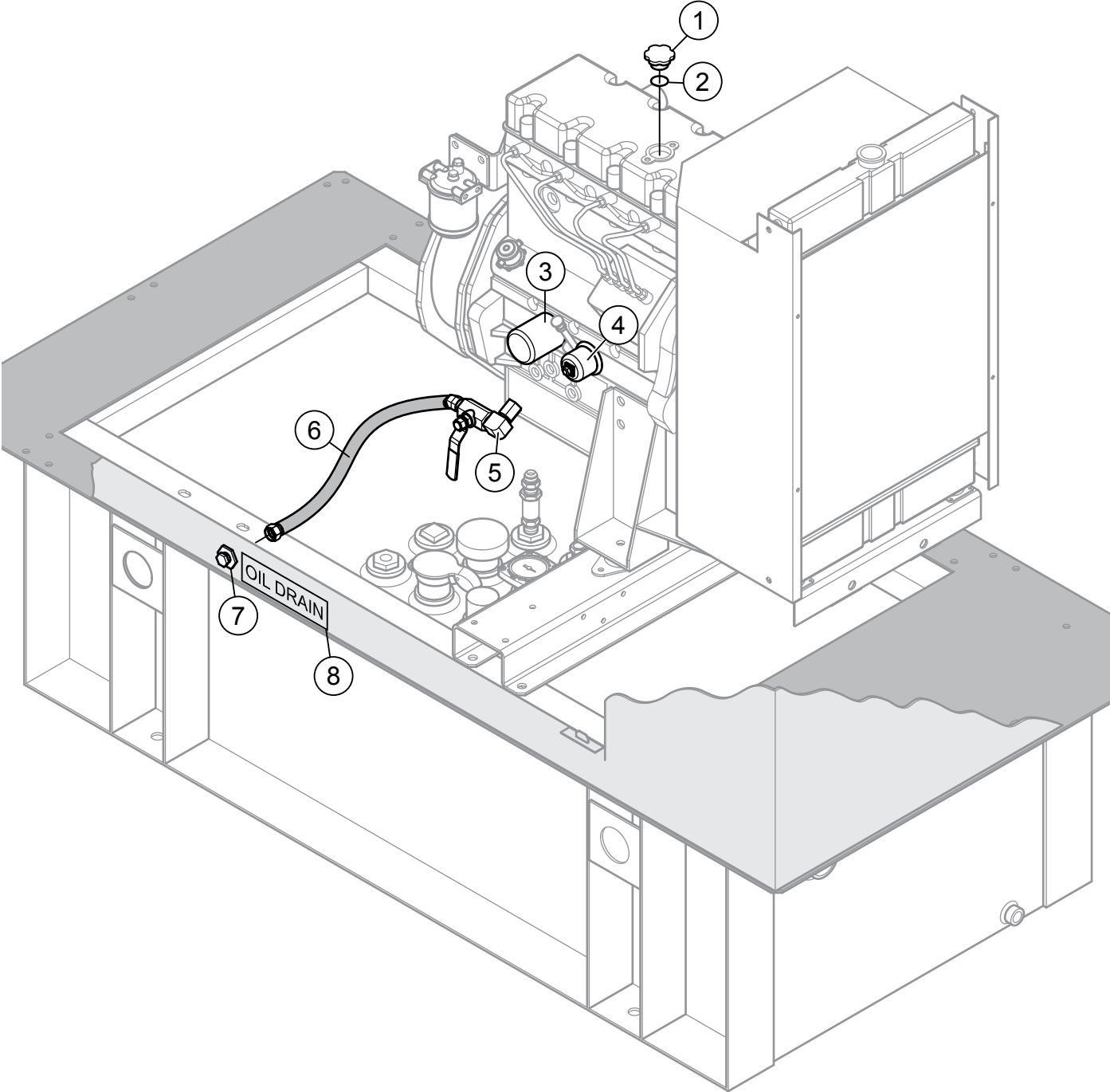

ENGINE OIL ASSY.

<u>NO.</u>	<u>PART NO.</u>	<u>PART NAME</u>	<u>QTY.</u>	<u>REMARKS</u>
1	U98436350	OIL FILLER CAP	1	
2	052100400	SEAL, O-RING	1	
3	140517050	OIL FILTER	1	
4	MEC003654	SENSOR, OIL PRESSURE	1	
4A		ADAPTER, BSPT-2-2.....	1.....	OBTAIN LOCALLY
5	EE18072	VALVE, LOCKING BALL, BRASS, 1/2IN FNPT	1	
6		HOSE, OIL DRAIN, GOODYEAR INSTRA-GRIP 3/8IN X 16 IN.	1.....	MAKE LOCALLY
7	218P-4	PLUG, OIL DRAIN, 1/4 IN. NPT BRASS	1	
8	EE7314	OIL DRAIN, PLACARD	1	

CONTROL PANEL ASSY.

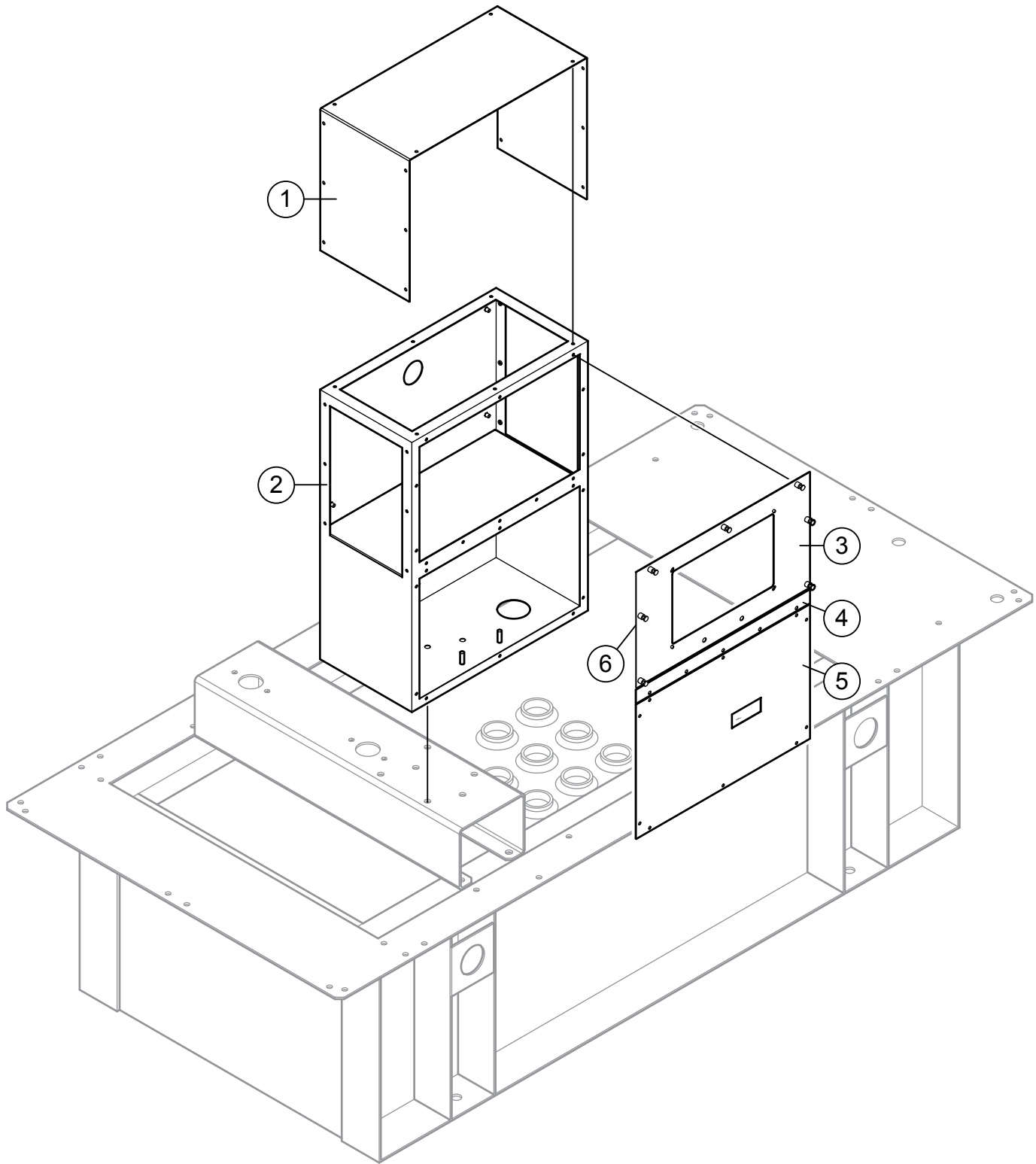

CONTROL PANEL ASSY.

<u>NO.</u>	<u>PART NO.</u>	<u>PART NAME</u>	<u>QTY.</u>	<u>REMARKS</u>
1	EE40941	COVER, TOP, CONTROL AND CIRCUIT BREAKER	1	
2	EE40940	FRAME, BOX, CONTROL AND CIRCUIT BREAKER	1	
3@	EE40944	PANEL, FRONT, CONTROL PANEL	1	
4@	EE40945	HINGE, FRONT RAIL	1	
5	EE40946	PANEL, FRONT, CIRCUIT BREAKER	1	
6	EE40942	ASSY, FRONT CONTROL PANEL W/ HINGE	1.....	INCLUDES ITEM W/@

CONTROLLER ASSY.

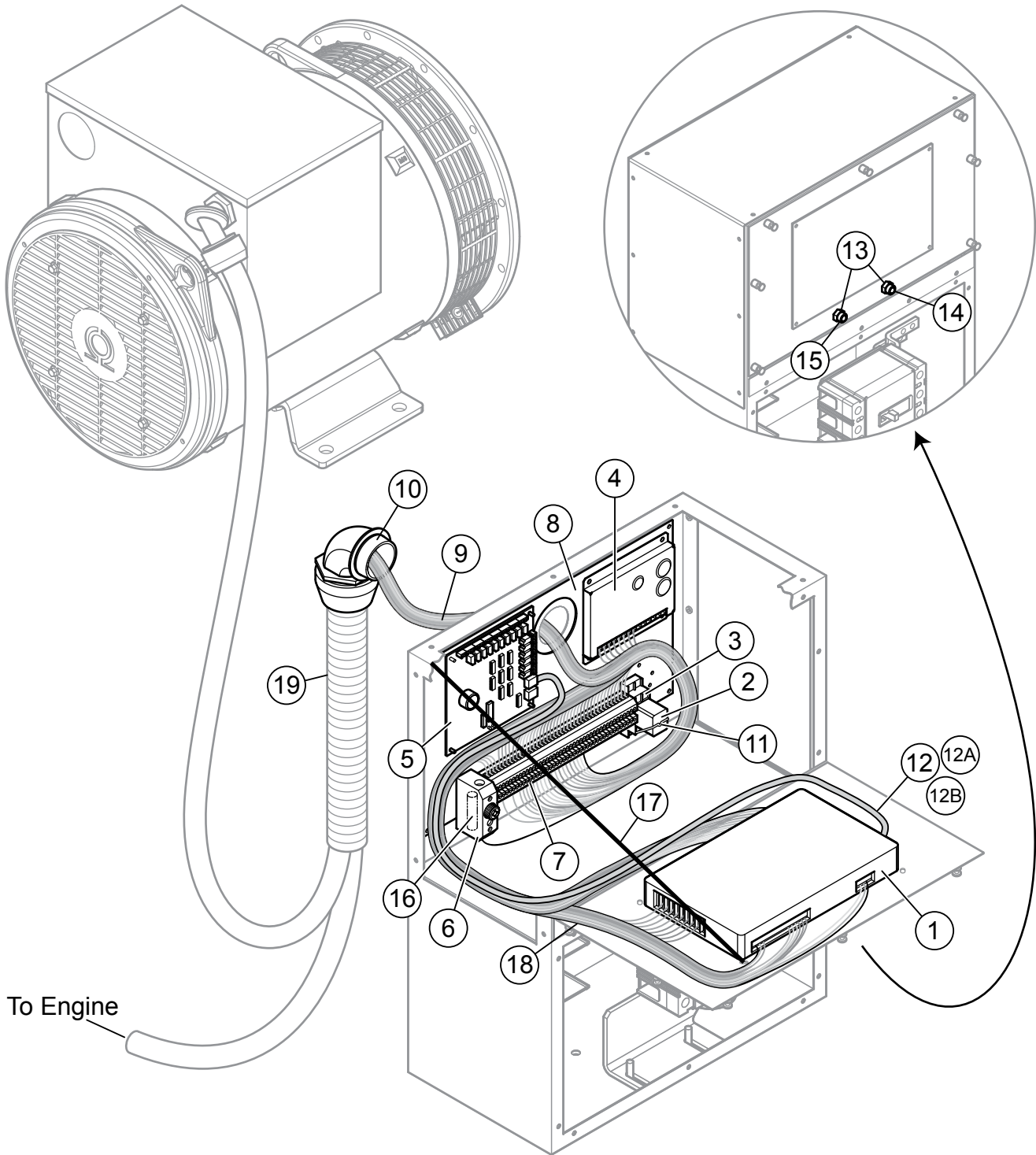

CONTROLLER ASSY.

<u>NO.</u>	<u>PART NO.</u>	<u>PART NAME</u>	<u>QTY.</u>	<u>REMARKS</u>
1	EE30144	CONTROLLER, ENG. & GEN., MEC-20, 12/24VDC	1	
2	EE26384	RELAY, 8 BLADE DPDT, 12VDC, 10A	1	
3	EE26385	BASE, RELAY, SNAP/SURFACE MOUNT	1	
4	EE23991	CONTROLLER, SPEED UNIT, 12/24V	1	
5	EE35388	MODULE, OUTPUT EXPAN., MEC 2/20 W/CABLE	1	
6	EE26108	BLCK, FUSE HOLDR, WEIDMULLER, POWER COMM	1	
7	EE26096	BLOCK, TERMINAL, SAK 2.5-WEIDMULLER	41	
8	EE41056	PANEL, BACK, MEC 20	1	
9	EE41503	WIRE HARNESS	1	
10	EE6010	FITTING, CONDUIT, NON-METAL., 2IN, 90 DEG	1	
11	EE26135	RETAINER, HLDDWN WIRE, MINI RELAY, 8	1	
12	MEC006950	CABLE, RJ45, STP, CAT5E, 6'	1	
12A	MEC006885	CABLE, ADAPTER, DB9M/RJ45	1	
12B	MEC006901	CABLE, ADAPTER, D39F/RJ45	1	
13	EE9949	NUT, SHAFT LOCK, POTENTIOMETER	2	
14	EE26026	POTENTIOMETER, 2K OHM +/-5%, 10 TURN, 2W	1	
15	EE2115	POTENTIOMETER, 5K OHM +/-5%, 10 TURN, 2W	1	
16	EE5812	FUSE, 10 AMP, GOULD SHAWMUT, MIDGT	1	
17	EE41430	LANYARD, CONTROL PANEL 21 -1/2 IN LNG	1	
18	EE41444	WIRE HARNESS, CONTROL BOX	1	
19	EE5980	CONDUIT, POLY TUFF TUBING, BLACK	1	

SADDLEBOX ASSY.

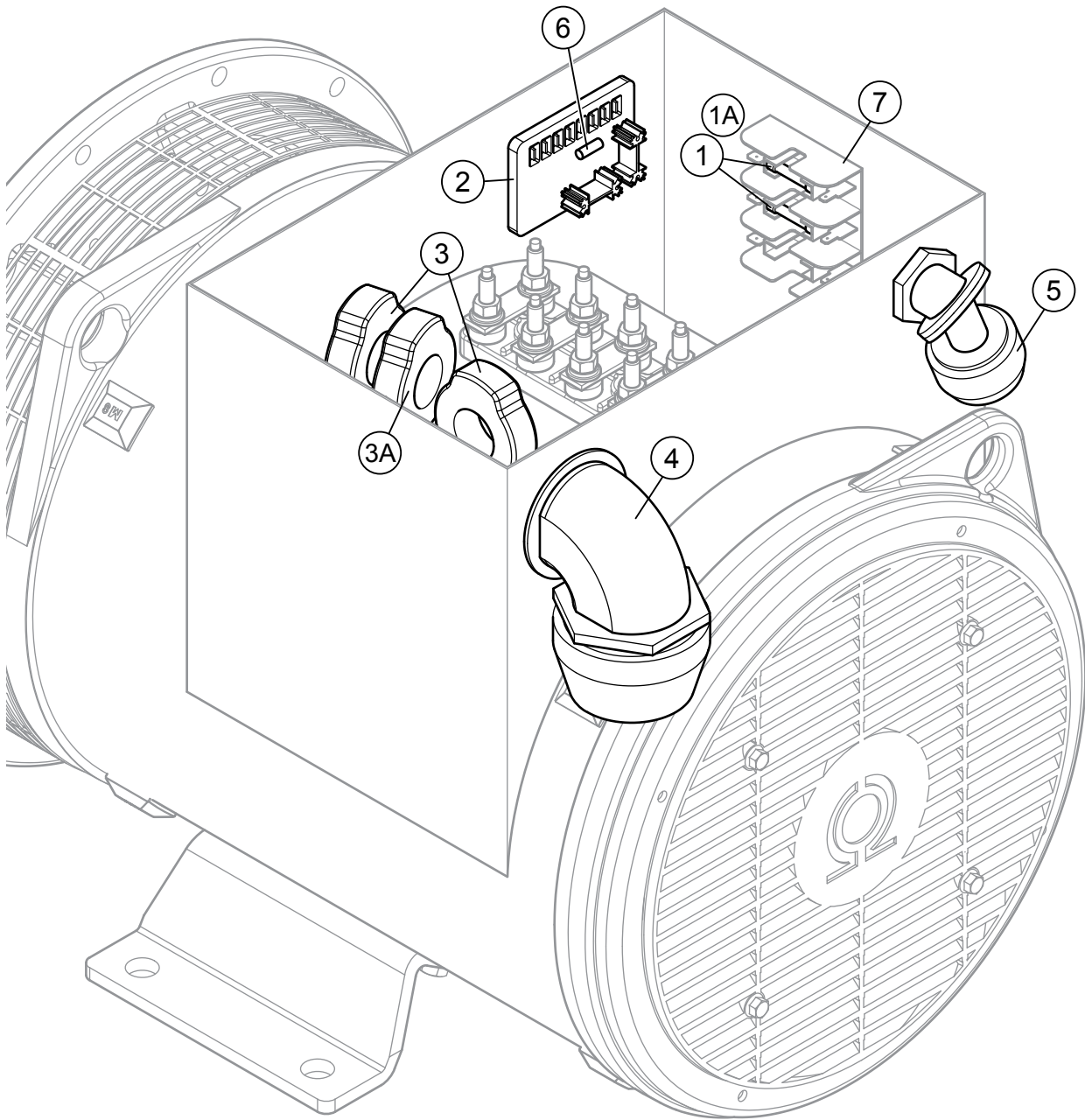

SADDLEBOX ASSY.

<u>NO.</u>	<u>PART NO.</u>	<u>PART NAME</u>	<u>QTY.</u>	<u>REMARKS</u>
1	EE5811	FUSE, 5 AMP.....	2.....	1 PHASE UNITS
1A	EE5811	FUSE, 5 AMP.....	3.....	3 PHASE UNITS
2	761594-01	VOLTAGE REGULATOR	1	
3	EE10470	TRANSFORMER, CURRENT, 100:5.....	2.....	1 PHASE UNITS
3A	EE10476	TRANSFORMER, CURRENT, 50:53.....	3.....	3 PHASE UNITS
4	EE6010	FITNG, CONDU., NON-METAL, 2IN, 90 DEG	1	
5	EE6023	CONNECTOR, SWIVELLOK	1	
6	A-527066-1	FUSE, 5 AMP, SLOW BLOW	1	
7	EE5759	BLOCK, MIDGET FUSE TYPE, 3 POLE	1	

CIRCUIT BREAKER ASSY.

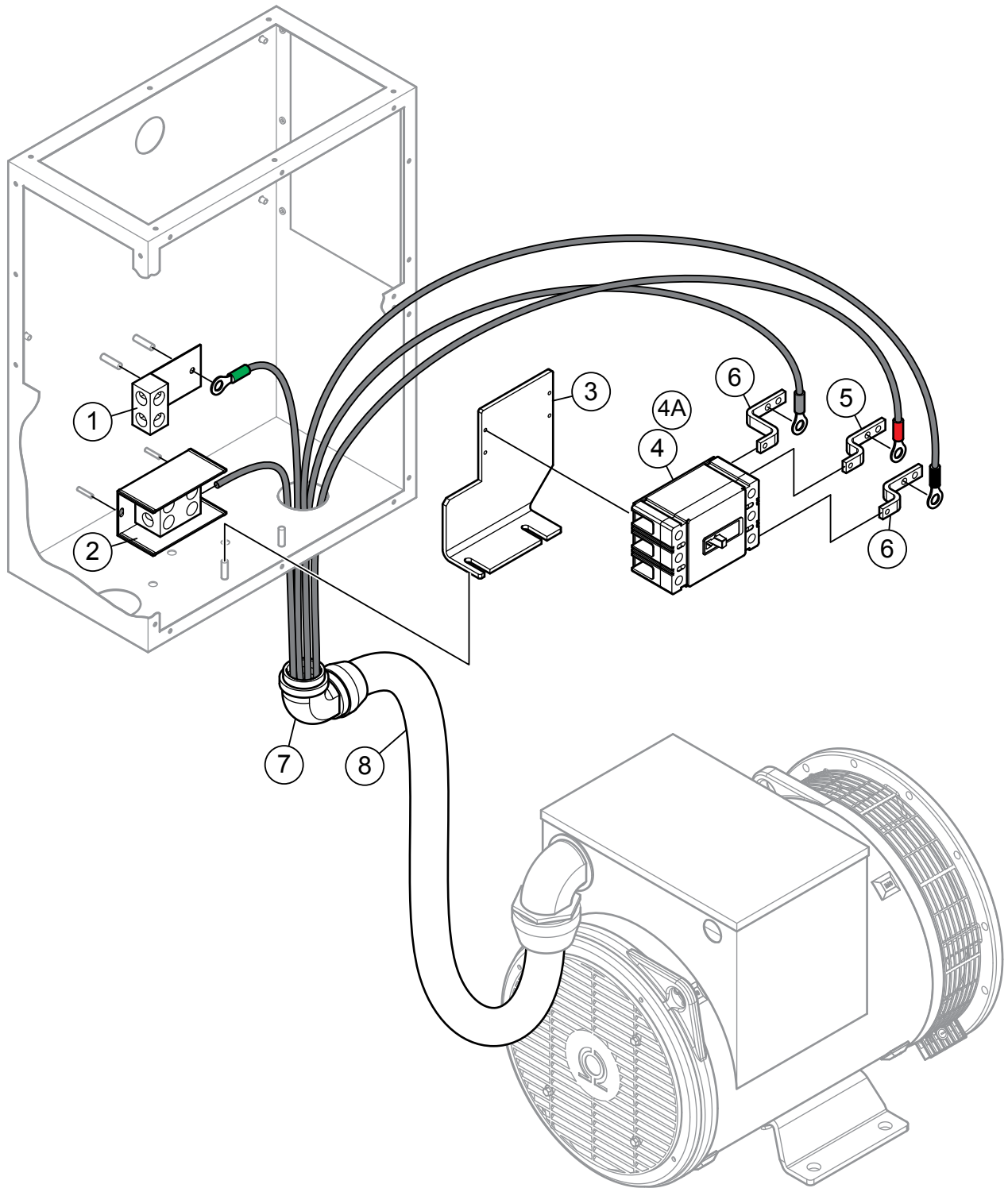

CIRCUIT BREAKER ASSY.

<u>NO.</u>	<u>PART NO.</u>	<u>PART NAME</u>	<u>QTY.</u>	<u>REMARKS</u>
1	EE41018	GROUND	1	
2	EE41019	NEUTRAL	1	
3	EE40948	BRACKET, SUPPORT CIRCUIT BREAKER	1	1 PHASE UNITS ONLY
4	EE10997	CB, CUTLER HAMMER, 3-POLE, 100A	1	1 PHASE UNITS ONLY
4A	EE38966	CB, CUTLER HAMMER, 3 POLE, 30A.....	1	3 PHASE UNITS ONLY
5	EE41048	BUS BAR, LONG, 1/4 IN COPPER BAR	1	
6	EE41047	BUS BAR, SHORT, 1/4 IN COPPER BAR.....	1	1 PHASE UNITS ONLY
6	EE41047	BUS BAR, SHORT, 1/4 IN COPPER BAR.....	2	3 PHASE UNITS ONLY
7	EE6009	CONDUIT, FITTING, 90°, NONMETALLIC	1	
8	EE5980	CONDUIT, 52 IN LONG	1	

CAMLOK ASSY.

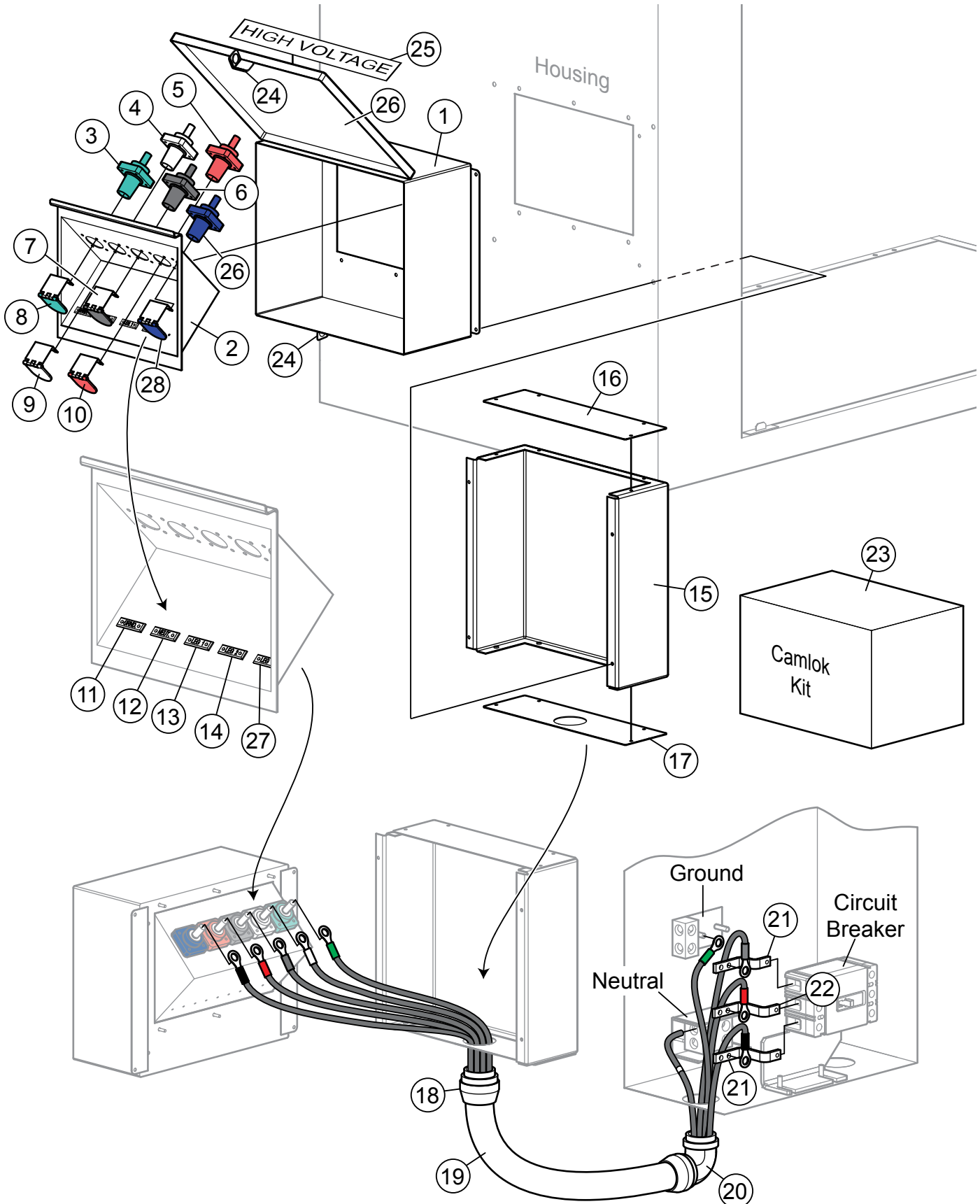

CAMLOK ASSY.

<u>NO.</u>	<u>PART NO.</u>	<u>PART NAME</u>	<u>QTY.</u>	<u>REMARKS</u>
1@	EE40216	BOX, CONTINUOUS HINGE, HOFFMAN	1	
2@	EE8314	PANEL, WELL, CAMLOK CONNECTION	1	
3@	EE6382	RECEPTACLE, PNL MNT, FEMALE, GREEN	1	
4@	EE6379	RECEPTACLE, PNL MNT, FEMALE, WHITE	1	
5@	EE6380	RECEPTACLE, PNL MNT, FEMALE, RED	1	
6@	EE6378	RECEPTACLE, PNL MNT, FEMALE, BLACK	1	
7@	EE41040	COVER, HINGED, BLACK	1	
8@	EE41044	COVER, HINGED, GREEN	1	
9@	EE41043	COVER, HINGED, WHITE	1	
10@	EE41041	COVER, HINGED, RED	1	
11@	EE23020	PLACARD, VINYL, GROUND	1	
12@	EE23019	PLACARD, VINYL, NEUTRAL	1	
13@	EE23016	PLACARD, VINYL, LEG 1	1	
14@	EE23017	PLACARD, VINYL, LEG 2	1	
15@	EE41471	COVER, CAMLOK PNL, INSIDE	1	
16@	EE41540	TOP, COVER, CAMLOK PNL, INSIDE	1	
17@	EE41546	BOTTM, COVER, CAMLOK PNL, INSIDE	1	
18@	EE6004	CONDUIT, FITTING, STR, 2IN	1	
19@	EE5980	CONDUIT, TUBING, 23 IN	1	
20@	EE6010	FITTING, CONDUIT, 90-DEG, 2IN	1	
21@	EE41047	BUS BAR, SHORT, 1/4 IN COPPER BAR	2	3 PHASE UNITS ONLY
22@	EE41048	BUS BAR, LONG, 1/4 IN COPPER BAR	1	
23	EE40866	CAMLOK ASSY	1	INCLUDES ITEMS W/@
24	EE40056	KIT, PADLOCK, BOX	1	
25	EE6449	DECAL, DANGER HIGH VOLTAGE	1	
26	EE6381	RECEPTACLE, PNL MNT, FEMALE, BLUE	1	3 PHASE UNITS ONLY
27	EE23018	PLACARD, VINYL, LEG 3	1	3 PHASE UNITS ONLY
28	EE41042	COVER, HINGED, BLUE	1	3 PHASE UNITS ONLY

TERMS AND CONDITIONS OF SALE — PARTS

PAYMENT TERMS

Terms of payment for parts are net 30 days.

FREIGHT POLICY

All parts orders will be shipped collect or prepaid with the charges added to the invoice. All shipments are F.O.B. point of origin. Multiquip's responsibility ceases when a signed manifest has been obtained from the carrier, and any claim for shortage or damage must be settled between the consignee and the carrier.

MINIMUM ORDER

The minimum charge for orders from Multiquip is \$15.00 net. Customers will be asked for instructions regarding handling of orders not meeting this requirement.

RETURNED GOODS POLICY

Return shipments will be accepted and credit will be allowed, subject to the following provisions:

1. A Returned Material Authorization must be approved by Multiquip prior to shipment.
2. To obtain a Return Material Authorization, a list must be provided to Multiquip Parts Sales that defines item numbers, quantities, and descriptions of the items to be returned.
 - a. The parts numbers and descriptions must match the current parts price list.
 - b. The list must be typed or computer generated.
 - c. The list must state the reason(s) for the return.
 - d. The list must reference the sales order(s) or invoice(s) under which the items were originally purchased.
 - e. The list must include the name and phone number of the person requesting the RMA.
3. A copy of the Return Material Authorization must accompany the return shipment.
4. Freight is at the sender's expense. All parts must be returned freight prepaid to Multiquip's designated receiving point.

5. Parts must be in new and resalable condition, in the original Multiquip package (if any), and with Multiquip part numbers clearly marked.
6. The following items are not returnable:
 - a. Obsolete parts. (If an item is in the price book and shows as being replaced by another item, it is obsolete.)
 - b. Any parts with a limited shelf life (such as gaskets, seals, "O" rings, and other rubber parts) that were purchased more than six months prior to the return date.
 - c. Any line item with an extended dealer net price of less than \$5.00.
 - d. Special order items.
 - e. Electrical components.
 - f. Paint, chemicals, and lubricants.
 - g. Decals and paper products.
 - h. Items purchased in kits.
7. The sender will be notified of any material received that is not acceptable.
8. Such material will be held for five working days from notification, pending instructions. If a reply is not received within five days, the material will be returned to the sender at his expense.
9. Credit on returned parts will be issued at dealer net price at time of the original purchase, less a 15% restocking charge.
10. In cases where an item is accepted, for which the original purchase document can not be determined, the price will be based on the list price that was effective twelve months prior to the RMA date.
11. Credit issued will be applied to future purchases only.

PRICING AND REBATES

Prices are subject to change without prior notice. Price changes are effective on a specific date and all orders received on or after that date will be billed at the revised price. Rebates for price declines and added charges for price increases will not be made for stock on hand at the time of any price change.

Multiquip reserves the right to quote and sell direct to Government agencies, and to Original Equipment Manufacturer accounts who use our products as integral parts of their own products.

SPECIAL EXPEDITING SERVICE

A \$35.00 surcharge will be added to the invoice for special handling including bus shipments, insured parcel post or in cases where Multiquip must personally deliver the parts to the carrier.

LIMITATIONS OF SELLER'S LIABILITY

Multiquip shall not be liable hereunder for damages in excess of the purchase price of the item with respect to which damages are claimed, and in no event shall Multiquip be liable for loss of profit or good will or for any other special, consequential or incidental damages.

LIMITATION OF WARRANTIES

No warranties, express or implied, are made in connection with the sale of parts or trade accessories nor as to any engine not manufactured by Multiquip. Such warranties made in connection with the sale of new, complete units are made exclusively by a statement of warranty packaged with such units, and Multiquip neither assumes nor authorizes any person to assume for it any other obligation or liability whatever in connection with the sale of its products. Apart from such written statement of warranty, there are no warranties, express, implied or statutory, which extend beyond the description of the products on the face hereof.

Effective: February 22, 2006

OPERATION AND PARTS MANUAL

HERE'S HOW TO GET HELP

PLEASE HAVE THE MODEL AND SERIAL
NUMBER ON-HAND WHEN CALLING

UNITED STATES

Multiquip Corporate Office

18910 Wilmington Ave.
Carson, CA 90746
Contact: mq@multiquip.com

Tel. (800) 421-1244
Fax (800) 537-3927

Service Department

800-421-1244
310-537-3700

Fax: 310-537-4259

Technical Assistance

800-478-1244

Fax: 310-943-2238

MQ Parts Department

800-427-1244
310-537-3700

Fax: 800-672-7877
Fax: 310-637-3284

Warranty Department

800-421-1244
310-537-3700

Fax: 310-943-2249

MEXICO

MQ Cipsa

Carr. Fed. Mexico-Puebla KM 126.5
Momoxpan, Cholula, Puebla 72760 Mexico
Contact: pmastretta@cipsa.com.mx

Tel: (52) 222-225-9900
Fax: (52) 222-285-0420

CANADA

Multiquip

4110 Industriel Boul.
Laval, Quebec, Canada H7L 6V3
Contact: jmartin@multiquip.com

Tel: (450) 625-2244
Tel: (877) 963-4411
Fax: (450) 625-8664

UNITED KINGDOM

Multiquip (UK) Limited Head Office

Unit 2, Northpoint Industrial Estate,
Globe Lane,
Dukinfield, Cheshire SK16 4UJ
Contact: sales@multiquip.co.uk

Tel: 0161 339 2223
Fax: 0161 339 3226

© COPYRIGHT 2011, MULTIQUIP INC.

Multiquip Inc, the MQ logo and the MQ Power logo are registered trademarks of Multiquip Inc. and may not be used, reproduced, or altered without written permission. All other trademarks are the property of their respective owners and used with permission.

This manual MUST accompany the equipment at all times. This manual is considered a permanent part of the equipment and should remain with the unit if resold.

The information and specifications included in this publication were in effect at the time of approval for printing. Illustrations, descriptions, references and technical data contained in this manual are for guidance only and may not be considered as binding. Multiquip Inc. reserves the right to discontinue or change specifications, design or the information published in this publication at any time without notice and without incurring any obligations.

Your Local Dealer is:

